

## **Best Practice I**

### **Empowering Rural Women by Education Them**

#### **CURRICULUM**

A gender-sensitive curriculum promotes inclusivity by addressing diverse perspectives and experiences. It aims to challenge stereotypes, foster empathy, and empower students to understand and respect gender diversity. Integrating topics related to gender equality, historical contributions of women, and LGBTQ+ issues helps create an educational environment that reflects the richness of human experiences, fostering a more equitable society.

# KHALSA COLLEGE FOR WOMEN, SIDHWAN KHURD

## Cross Cutting Issues relevant to Gender in Curriculum

### 2023-24

Programme	Subject	Semester	Paper	Course code	Topic
Bachelor of Arts	Political science	III	Indian government and politics	BA040	Unit II- Fundamental rights (Art 14-32): meaning, explanation, evolution (criticism and importance) Fundamental duties-meaning, explanation, evolution (criticism and importance)
Bachelor of Arts	History and culture of Punjab	VI	History and culture of Punjab: post independence period	BA094	Gender discrimination
Bachelor of Arts	Sociology	V	Society in India	BA079	Under privileged sections- women, physically disabled, scheduled casts and scheduled tribes: measures to improve their status
Bachelor of Arts	Sociology	VI	Disorganisation emerging problems	BA095	Familial problems: domestic violence, violence against children, female headed households, problems of working women.
Bachelor of Arts	History and culture of Punjab	IV	HCP 18 <sup>th</sup> and early 19 <sup>th</sup> centuries	BA062	Social life with special reference to the position of women
Bachelor of Arts	History and culture of Punjab	I	History and culture of punjab from the earliest times to the Mauryan period	BA014	Position of women: Harappan, early vedic and later vedic age.
Bachelor of Arts	Sociology	II	Sociology stratification	BA031	Forms of social stratification: casts, class, race and gender. interface between caste and class
Bachelor of Arts Bachelor of Education 4 year Course	History and Culture of Punjab	I	History and culture of Punjab	BABED-HCPC11	Position of women: Harappan, early vedic and late vedic age.
Bachelor of Arts, science, commerce, computer applications, BA-B.Ed, B.Sc-B.Ed	Environment Education	II	Environmental Education, Road Safety Education and Violence Against Women / Children	ENV017	Violence against women and children

Bachelor of Commerce	Commerce	VI	Social and Business Ethics	BCM 604	Gender Issue, Harassment and Discrimination
<b>Programme</b>	<b>Subject</b>	<b>Semester</b>	<b>Paper</b>	<b>Course code</b>	<b>Topic</b>
Bachelor of Arts	Political science	II	Political Theory-II	BA024	<ol style="list-style-type: none"> <li>1. Rights and duties: meaning, types, correlation between the two</li> <li>2. Universal declaration of human rights: meaning of human rights, nature and classification</li> <li>3. Liberty: Meaning, Types and its safeguards</li> <li>4. Equality: Meaning, types and relationships between liberty and equality</li> <li>5. Justice: Meaning and its various dimensions.</li> </ol>
Bachelor of Arts	Punjabi	VI	Compulsory Punjabi	BA082	Anoop Kaur
Bachelor of Arts	Punjabi	IV	Elective Punjabi	BA052	Kahaani Sangreh
Bachelor of Arts-Bachelor of Education 4 year Integrated Course	Punjabi	IV	Compulsory Punjabi	BABED-PBIC42	Chhe Chalan
Bachelor of Arts	Police Administration	II	Constitution of India	BA146	National Commission for Women
Master of Arts	Political Science	I	Key concepts in political analysis	CPA	<ol style="list-style-type: none"> <li>a. Liberty-Negative and positive models and political liberty, freedom of expression, social conditioning and self realization.</li> <li>b. Equality and justice- why equality, equality of what and difference rights-natural, legal rights, human rights, three generations of rights, individual and group rights.</li> </ol>
Master of Arts History	History	III	Gender Relations in Modern India	HIS 601	Gender relations in modern India
Master of Arts English	English	III	Indian writing in English	IWE	Githa Hariharan The Thousand Faces of Night
Master of Arts English	English	III	American Literature I	AL I	Adrieme Rich: Planetarium, Cartographies of Silence , Stepping Backward

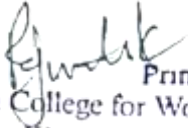

Master of Arts English	English	IV	Literature Theory II	LTH I	Elaine Showalter: Feminist Criticism in the wilderness
Master of Arts English	English	IV	Indian writing in Translation	IWT	Mahashiveta Devi, 'Draupadi' and The Breast Giver "Urmil Pawar, " The Weave of my Life" A Dalit Woman Memoirs
Master of Arts English	English	IV	American Literature II	AML II	Sandra Cisneros: The House on Mango street
Master of Arts Political Science	Political Science	I	Indian Politics: Political Processes	IP	Class, Gender, Electoral Politics
Master of Arts Political Science	Political Science	III	Indian Political Thought	IPT-I	Meaning , Nature and critical evaluation with special reference to gender, caste and modernity
Master of Arts Political Science	Political Science	IV	Decentralized Governance and local level institutions in India	DGI	Challenges of Governance at the local level autonomy, finance, personnel, participation.
Master of Arts History	History	I	Modern India : Political Processes	HIS 211	Women Participation in National Movement
Master of Arts History	History	II	USA (1820-1973)	HIS 812	Feminist Movement
Master of Arts	Punjabi	IV	Punjabi Saak ate Rang Manch da Adhyaan	PNR II	Naari Chetna
Master of Arts	English	IV	Indian Writing in Translation	IW II	Urmila Pawar- The Weave of my Life
Master of Arts	English	II	Approaches to Literary Criticism-II	ALC II	Wilfred's 'Feminism and Gender Studies' A Handbook of critical Approaches to Literature. Charlotte Krolokke and Ann Scott Sorensen Three Waves of Feminisim, Gender Communication and Theory and Analysis From Silence to Performance Judith-Butler ' Performative Acts and Gender Constitution
Master of Arts	English	IV	Critical Theory-II	CT II	Judith-Butler ' Performative Acts and Gender Constitution

  
 Principal,  
 Khalsa College for Women,  
 Sidhwan Khurd (Ludhiana).



# HOSTEL

Ensuring safety is our top priority. We have implemented robust security measures to create a safe and secure environment within the hostel premises for all girls.





 **GPS Map Camera**

Sidhwan Khurd, Punjab, India  
RHH2+8XG, Sidhwan Khurd, Punjab 142024, India  
Lat 30.828647°  
Long 75.553156°  
15/11/23 10:07 AM GMT +05:30



# FEEDBACK

The college has a feedback and suggestion box to gather valuable inputs and ideas from students and staff.





**Khalsa College for Women, Sidhwan Khurd (Ludhiana)**

**Grievance Redressal Committee Report (2023-24)**

Sr. No	Student Name	Class	Roll No	Grievance
1	Muskaan Begum	B.Sc.B.Ed Sem -II	2415	Hostel Lunch Break During College Time
2	Shreya Shirma	B.Sc.B.Ed Sem -II	2413	Lack of Clean Toilets of College
3	Manpreet Kaur	M.Com Sem-III	3503	Regarding Time of College Assembly
4	Manpreet Kaur	M.Com Sem-III	3503	Usage of Curtains at Back Stage of Auditorium

A Meeting of Grievance Redressal Committee was held on 10.02.2024 and above mentioned Grievances were discussed and following Measures were taken.

1. Hostel Lunch Break was Given from 1:00 PM to 1:30 PM During College Time.
2. Toilets Were Cleaned by Mrs. Parmjit Kaur (Sweeper) of College.
3. College Assembly Take Place Once in Week.
4. Curtains were put at Back Stage of Auditorium.

**Grievance Redressal Committee**

1. S.Gagandeep Aulakh *S.Aulakh*
2. Ms.Bhagwant Kaur *B.Kaur*

(15/2/24).

*27/11/24*  
Principal,  
Khalsa College for Women,  
Sidhwan Khurd (Ludhiana)

To  
The Principal  
Khalsa College for women  
Sidhwan Khurd  
Ludhiana

Date:—

Subject:— Application regarding timing of hostel lunch break during college hours.

Respected Madam,

With due respect I beg to say that I am the student of your college. I am a hosteller staying in room no. 27, hostel No. 2. Many times all the hostellers suffered from this problem i.e. timing of hostel lunch break during college hours. The hostel mess timing is 12:30 PM to 2:00 PM. but at the time we have all the important classes. So I requested you to give us time for lunch break so that our study is not disturbed. So I do hope you will pay attention to the most essential problem.

Yours obediently

Muskaan Begum  
B.Sc B.Ed (Sem II)

2415

GA-lal

BKaur

To  
The Principal  
Khalsa College for Women  
Sidhwan Khurd  
Ludhiana

Date: —

Subject: → Application regarding lack of clean toilets of  
College

Respected Mam

With due respect I beg to say that I am student of your college. Many times we have suffered from this problem, i.e. lack of clean toilets of college. I want to bring to your kind notice how the toilets of the college remain very dirty and no antiseptic spraying is done in them. This has been going on now for some time. There were no proper flushing and cleaning of the pots of the toilets. There is no dustbin in the toilet.

Since toilet is an essential facility, proper cleanliness and maintenance is must. I do hope you will pay attention to this most essential problem.

Yours obediently

Shreya Sharma  
BSC BEd (Sem II)  
2413

CAulakh  
Bkaur



To  
The Principal  
Khalsa College For Women  
Sidhwan Khurd  
Ludhiana

Date:-

Subject:- Application regarding time of college  
-assembly.

Respected Madam,

With due respect I beg to say that I am student of class M.com in your esteemed institution. It is analysis that the college assembly took a couple of minutes - hours in which we are provided with alot of instructions and information related events and all. No doubt it is very useful to us. But somehow it took alot of time due to which some of our initial lectures are missed by chance. I request if possible the assembly must be concised in nature. In your response.

Yours Obediently  
Manpreet Kaur

M.com II  
3503

CA - Jee  
Bkaur

To  
The Principal  
Khalsa College For Women  
Sidhwan Khurd  
Ludhiana

Date:-

Subject- Application related to usage of curtains  
at back stage of auditorium.

Respected Madam,

With due respect i beg to say that i am student  
in your reputed college. Many times we have  
suffered from this problem. Curtains are not  
available at back stage of our auditorium. It  
becomes difficult to manage it. All the performers  
need back stage with proper maintenance for  
and as a part of good environment. I  
request you to please take this into consideration  
I shall be very thankful to you. ~~and~~ and the entire  
management.

Yours Obediently  
Manpreet Kaur

M.com II

3503

G. Arora

Bhagwant  
Kaur

# MENTORING

Our students benefit from personalized guidance as they are counseled by dedicated mentors. This ensures a supportive and enriching academic journey for the girls.

## Khalsa College for Women, Sidhwan Khurd (Ludhiana)

### Mentor Mentee Cum Buddy Groups Session 2023-24

All the students are informed to note down the contact number of your mentor and other teachers. In case of any query/problem, you can contact your respective mentor/teacher.

CLASS	ROLL NO	TEACHERS NAME	Contact Number of Mentor
BA-I	1-18	Ms. Resopa kaur Rai	7347217881
	19-36	Dr. Balwinder Kaur	9417888910
	37-54	Ms. Inderjit Kaur	9417085785
	55 onwards	Dr. Paramdeep Singh	7503171000
BA-II	401-420	Dr. Geetanjali Arora	9814454176
	421-439	Mrs. Hardeep Kaur	8360060890
BA-III	701-727	Dr. Jasdeep Kaur	9855102728
BCA-I	1001-1024	Mrs. Jaspreet Kaur	9646478781
		Mrs. Ramanpreet Kaur	9463528206
BCA-II&III	1101-1111 1201-1206	Mr. Puneet Wadhwa	9814439520
B.Sc (Med) I	1301-1307	Dr. Amandeep Kaur	9463911572
B.Sc (Med) II	1501		
B.Sc (Med) III	1701-1704		
B.Sc (N.Med) I	1401-1408	Mr. Ashish Kumar	7508969684
B.Sc (N.Med) II	1601-1603		
B.Sc (N.Med) III	1801-1807		
B.Com-I	1901-1923		
B.Com-I	1924-1946	Mrs. Harwinder Kaur	6280812009
	1947-1956	Dr. Gagandeep Dharni	9988943388
	2001-2017	Dr. Amandeep Kaur	9463911572
B.Com-II	2001-2017	Ms. Rajni	8427363672
B.Com- III	2101-2120	Mr. Ashwani Jain	8146774444
BA B.Ed-I	2201-2222	Ms. Bhagwant Kaur	7973266334
BA B.Ed-II	2251-2258	Dr. Parmjit Kaur	6280851611
BA B.Ed-III	2301-2308		
BA B.Ed-IV	2351-2356		
B.Sc B.Ed-I	2401-2419		
B.Sc B.Ed-III	2501-2502	S. Gagandeep Anlakh	9872158823
M.A.(Pbi.) I, II	2601-02 2701-02	Dr. Navdip Kaur	9855699333
	2801-05		
M.A (His.) I	3001-04		
M.A.(Eng.) I, II	3101-04	Mrs. Karamdeep Kaur	9988822621
	3201		
M.A (Pol Sci.) I	3401-3408		
M.Com I, II	3501-03		

*Ashwani Jain*

Date: 16.08.2023

*[Signature]*  
Principal  
Khalsa College for Women,  
Sidhwan Khurd (Ludhiana)



# GRIEVANCE REDRESSAL CELL

Our college is dedicated to ensuring a positive experience for every student. The Grievance Redressal Cell is in place to address any concerns promptly.

Prospectus 2023-24

## GRIEVANCE REDRESSAL CELL

ਵਿਦਿਆਰਥਣਾਂ ਲਈ ਅਕਾਦਮਿਕ ਮਾਹੌਲ ਨੂੰ ਹੋਰ ਵਧੀਆ ਬਣਾਉਣ ਲਈ ਕਾਲਜ ਦੇ ਸੀਨੀਅਰ ਅਧਿਆਪਕਾਂ ਵੱਲੋਂ ਵਿਦਿਆਰਥਣਾਂ ਦੇ ਦਿੱਤੇ ਸੁਝਾਅ/ਸ਼ਿਕਾਇਤਾਂ ਦੇ ਆਧਾਰ 'ਤੇ ਤੁਰੰਤ ਬਣਦੀ ਕਾਰਵਾਈ ਕੀਤੀ ਜਾਂਦੀ ਹੈ। ਸੀਨੀਅਰ ਵਿਦਿਆਰਥਣਾਂ ਵੱਲੋਂ ਰੈਗਿੰਗ ਕਰਨੀ ਜਾਂ ਮਾਨਸਿਕ ਪ੍ਰੇਸ਼ਾਨੀ ਦੇਣੀ ਕਾਨੂੰਨ ਅਪਰਾਧ ਹੈ। ਨਿਯਮ ਦੀ ਉਲੰਘਣਾ ਕਰਨ ਤੇ ਸਖ਼ਤ ਕਾਰਵਾਈ ਕੀਤੀ ਜਾਵੇਗੀ। (ਸੁਪਰੀਮ ਕੋਰਟ ਦੇ ਹੁਕਮਾਂ ਅਨੁਸਾਰ)

## Annual Staff Duty

### 38. Grievance Redressal cell

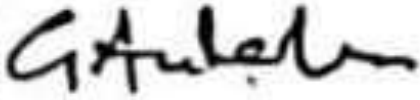
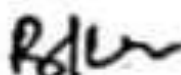
- S. Gagandeep Aulakh 
- M/s Bhagwant Kaur 



# WOMEN HARASSMENT CELL



Immediate necessary action is taken in response to any problem faced by the students. Ragging and physical or mental harassment will lead to strict action.(As per directions of Supreme Court)

## CELL FOR PREVENTION OF HARASSMENT OF WOMEN AT WORK PLACES

ਵਿਦਿਆਰਥਣਾਂ ਦੀ ਕਿਸੇ ਵੀ ਪ੍ਰੇਸ਼ਾਨੀ ਦਾ ਹੱਲ ਕਰਨ ਲਈ ਅਧਿਆਪਕਾਂ ਵੱਲੋਂ ਤੁਰੰਤ ਬਣਦੀ ਕਾਰਵਾਈ ਕੀਤੀ ਜਾਂਦੀ ਹੈ। ਸੀਨੀਅਰ ਵਿਦਿਆਰਥਣਾਂ ਵੱਲੋਂ ਰੈਗਿੰਗ ਕਰਨੀ ਜਾਂ ਮਾਨਸਿਕ ਪ੍ਰੇਸ਼ਾਨੀ ਦੇਣੀ ਕਾਨੂੰਨ ਅਪਰਾਧ ਹੈ। ਨਿਯਮ ਦੀ ਉਲੰਘਣਾ ਕਰਨ ਤੇ ਸਖ਼ਤ ਕਾਰਵਾਈ ਕੀਤੀ ਜਾਵੇਗੀ (ਸੁਪਰੀਮ ਕੋਰਟ ਦੇ ਹੁਕਮਾਂ ਮੁਤਾਬਿਕ)

## Annual Staff Duty

### **24. Committee for Prevention of Sexual Harassment of Women at work place**

- Ms Rajni 
- Dr Geetanjali Arora 

## DISCIPLINARY RULES

1. ਕਾਲਜ ਕੈਂਪਸ ਵਿੱਚ ਸਥਿੱਤ ਗੁਰਦੁਆਰਾ ਸਾਹਿਬ ਅੰਦਰ ਅਦਬ-ਸਤਿਕਾਰ ਨਾਲ ਵਿਚਰਿਆ ਜਾਵੇ। ਮਰਿਆਦਾ ਦੀ ਉਲੰਘਣਾ ਕਰਨ ਵਾਲੀ ਵਿਦਿਆਰਥਣ ਨੂੰ ਜੁਰਮਾਨਾ ਕੀਤਾ ਜਾਵੇਗਾ।
  2. ਕਿਸੇ ਵੀ ਵਿਦਿਆਰਥਣ ਨੂੰ ਕਾਲਜ ਸਮੇਂ ਦੌਰਾਨ ਛੁੱਟੀ ਲਈ ਸੰਬੰਧਿਤ ਕਲਾਸ ਦੇ ਇੰਚਾਰਜ ਜਾਂ ਟਿਊਟਰ ਦੀ ਆਗਿਆ ਲੈਣੀ ਜ਼ਰੂਰੀ ਹੈ।
  3. ਕਾਲਜ ਵਿੱਚ ਬੁਰਾ-ਵਰਤਾਓ ਜਾਂ ਨਿਯਮਾਂ ਦੀ ਉਲੰਘਣਾ ਕਰਨ ਵਾਲੀਆਂ ਵਿਦਿਆਰਥਣਾਂ ਦੇ ਖਿਲਾਫ਼ ਸਖ਼ਤ ਕਾਰਵਾਈ ਕੀਤੀ ਜਾਵੇਗੀ।
  4. ਕਾਲਜ ਵਿੱਚ ਵਿਦਿਆਰਥਣਾਂ ਲਈ ਸਵੇਰ ਦੀ ਸਭਾ ਦਾ ਆਯੋਜਨ ਹੁੰਦਾ ਹੈ। ਜਿਸ ਵਿੱਚ ਕਈ ਮਹੱਤਵਪੂਰਨ ਜਾਣਕਾਰੀਆਂ, ਵਿਸ਼ੇਸ਼ ਦਿਹਾੜੇ, ਭਾਸ਼ਣ ਅਤੇ ਪੀ.ਪੀ.ਟੀ. ਆਦਿ ਗਤੀਵਿਧੀਆਂ ਕਰਵਾਈਆਂ ਜਾਂਦੀਆਂ ਹਨ। ਸਾਰੇ ਵਿਦਿਆਰਥੀਆਂ ਲਈ ਸਵੇਰ ਦੀ ਸਭਾ ਵਿੱਚ ਸ਼ਾਮਿਲ ਹੋਣਾ ਜ਼ਰੂਰੀ ਹੈ।
  5. ਪ੍ਰਿੰਸੀਪਲ ਦੀ ਆਗਿਆ ਤੋਂ ਬਿਨਾਂ ਵਿਦਿਆਰਥਣਾਂ ਨੂੰ ਇਕੱਠੇ ਕਰਨ ਦੀ ਸਖ਼ਤ ਮਨਾਹੀ ਹੈ।
  6. ਕਾਲਜ ਦੇ ਪਤੇ ਤੇ ਪਾਰਸਲ ਮੰਗਵਾਉਣ ਦੀ ਇਜਾਜ਼ਤ ਨਹੀਂ ਹੋਵੇਗੀ।
  7. ਕਿਸੇ ਵੀ ਵਿਦਿਆਰਥਣ ਦੇ ਮਹਿਮਾਨਾਂ ਨੂੰ ਕਾਲਜ ਕੈਂਪਸ ਵਿੱਚ ਮਿਲਣ ਦੀ ਆਗਿਆ ਨਹੀਂ ਹੋਵੇਗੀ।
  8. ਕਾਲਜ ਵਿੱਚ ਫੁੱਲ ਤੋੜਨਾ, ਬੂਟੇ ਪੁੱਟਣੇ, ਕੰਧਾਂ ਅਤੇ ਡੈਸਕਾਂ ਉੱਪਰ ਲਿਖਣਾ ਸਖ਼ਤ ਮਨ੍ਹਾਂ ਹੈ।
  9. ਕਾਲਜ ਦੇ ਸਾਰੇ ਸਮਾਗਮਾਂ ਵਿੱਚ ਸਮੂਹ ਵਿਦਿਆਰਥਣਾਂ ਦੀ ਹਾਜ਼ਰੀ ਲਾਜ਼ਮੀ ਹੈ।
  10. ਵਿਦਿਆਰਥੀਆਂ ਨੂੰ ਕਾਲਜ ਸਮੇਂ ਦੌਰਾਨ ਆਪਣਾ ਆਈ ਕਾਰਡ ਆਪਣੇ ਨਾਲ ਰੱਖਣਾ ਚਾਹੀਦਾ ਹੈ। ਅਜਿਹਾ ਨਾ ਕਰਨ ਤੇ ਅਨੁਸ਼ਾਸਨੀ ਕਾਰਵਾਈ ਕੀਤੀ ਜਾ ਸਕਦੀ ਹੈ।
  11. ਵਿਦਿਆਰਥਣਾਂ ਨੂੰ ਛੁੱਟੀ ਲੈਣ ਲਈ ਪਹਿਲਾਂ ਬਿਨੈ ਪੱਤਰ ਦੇਣਾ ਪੈਂਦਾ ਹੈ ਛੁੱਟੀ ਲਈ ਬਿਨੈ ਪੱਤਰ ਉਪਰ ਮਾਪਿਆਂ ਜਾਂ ਸਰਪ੍ਰਸਤ ਦੇ ਦਸਖਤ ਹੋਣੇ ਜ਼ਰੂਰੀ ਹਨ। ਗੈਰ ਹਾਜ਼ਰੀ ਦੇ ਦਿਨਾਂ ਤੋਂ 10 ਰੁਪਏ ਰੋਜ਼ਾਨਾ ਜੁਰਮਾਨਾ ਹੋਵੇਗਾ। ਛੁੱਟੀ ਲੈਣ ਸਮੇਂ ਵਿਦਿਆਰਥਣ ਤੇ ਮਾਪਿਆਂ ਕੋਲ ਆਧਾਰ ਕਾਰਡ ਦੀ ਕਾਪੀ ਹੋਣੀ ਲਾਜ਼ਮੀ ਹੈ।
  12. ਵਿਦਿਆਰਥਣ ਨੂੰ ਯੂਨੀਵਰਸਿਟੀ ਇਮਤਿਹਾਨਾਂ ਵਿੱਚ ਬੈਠਣ ਲਈ 75% ਹਾਜ਼ਰੀਆਂ ਹੋਣੀਆਂ ਜ਼ਰੂਰੀ ਹਨ। ਜਿੰਨ੍ਹਾਂ ਵਿਦਿਆਰਥਣਾਂ ਦੀ ਹਾਜ਼ਰੀ 75% ਤੋਂ ਘੱਟ ਹੋਵੇਗੀ ਉਹਨਾਂ ਨੂੰ ਇਮਤਿਹਾਨਾਂ ਵਿੱਚ ਬੈਠਣ ਦੀ ਇਜਾਜ਼ਤ ਨਹੀਂ ਮਿਲੇਗੀ ਵਿਦਿਆਰਥਣਾਂ ਦੇ ਘਰ ਇਸ ਸੰਬੰਧੀ ਸੂਚਨਾ ਈ-ਮੇਲ ਰਾਹੀਂ ਭੇਜੀ ਜਾਵੇਗੀ।
  13. ਇਮਤਿਹਾਨਾਂ ਦੌਰਾਨ ਬਿਮਾਰੀ ਦੀ ਛੁੱਟੀ ਲਈ ਮੈਡੀਕਲ ਸਰਟੀਫਿਕੇਟ ਦੇਣਾ ਜ਼ਰੂਰੀ ਹੋਵੇਗਾ।
  14. ਸਾਰੇ ਵਿਸ਼ਿਆਂ ਸੰਬੰਧੀ ਇੰਟਰਨਲ ਅਸੈਸਮੈਂਟ MST ਇਮਤਿਹਾਨਾਂ ਵਿੱਚ ਪ੍ਰਾਪਤ ਅੰਕਾਂ ਅਤੇ ਕਲਾਸਾਂ ਵਿੱਚ ਹਾਜ਼ਰੀ ਦੇ ਅਨੁਸਾਰ ਲਗਾਈ ਜਾਵੇਗੀ।
  15. ਕਲਾਸ ਵਿੱਚ ਮੋਬਾਇਲ ਫੋਨ ਦੀ ਵਰਤੋਂ ਦੀ ਆਗਿਆ ਨਹੀਂ ਹੈ।
  16. ਕੋਵਿਡ-19 ਦੀ ਮਹਾਂਮਾਰੀ ਤੋਂ ਬਚਾਅ ਲਈ ਸਰਕਾਰ ਵੱਲੋਂ ਸਮੇਂ-ਸਮੇਂ ਤੇ ਜਾਰੀ ਕੀਤੀਆਂ ਹਦਾਇਤਾਂ ਦੀ ਪਾਲਣਾ ਕਰਨੀ ਵਿਦਿਆਰਥਣਾਂ ਲਈ ਲਾਜ਼ਮੀ ਹੋਵੇਗੀ ਤਾਂ ਜੋ ਆਪਣੇ ਆਪ ਨੂੰ ਸੁਰੱਖਿਅਤ ਰੱਖਿਆ ਜਾ ਸਕੇ।
- ਨੋਟ: ਇਹ ਪ੍ਰਾਸਪੈਕਟਸ ਕੋਈ ਕਾਨੂੰਨੀ ਦਸਤਾਵੇਜ਼ ਨਹੀਂ ਹੈ। ਪੰਜਾਬ ਸਰਕਾਰ, ਪੰਜਾਬ ਯੂਨੀਵਰਸਿਟੀ ਜਾਂ ਪ੍ਰਿੰਸੀਪਲ ਦੀ ਆਗਿਆ ਅਨੁਸਾਰ ਕਿਸੇ ਵੀ ਨਿਯਮ ਨੂੰ ਬਦਲਿਆ ਜਾ ਸਕਦਾ ਹੈ।

### Say 'NO' to Ragging

After the admission in the college, it is compulsory for each student and every parent to submit an online undertaking at [www.antiragging.in](http://www.antiragging.in). Students in distress due to ragging related incidents may call the national Anti-ragging Helpline 1800-1805522 (24x7 Toll Free) or e-mail the Anti-Ragging helpline at [helpline@antiragging.in](mailto:helpline@antiragging.in) For any other information regarding ragging, please visit the UGC website i.e. [www.ugc.ac.in](http://www.ugc.ac.in) & [www.antiragging.in](http://www.antiragging.in)

## Annual Staff Duty

### 11. Anti Ragging Squad

- Mrs Ramanpreet Kaur
- Dr Paramjit Kaur



# College Activities

## **Khalsa College for Women, Sidhwan Khurd celebrates Teej Festival**

Traditional festival of Teej was celebrated with gaiety and fervor at Khalsa College for Women, Sidhwan Khurd, premier rural women institution of the region on August 17, 2023. Dr. Amandeep Kaur, Principal (Addl. Charge) of the college was the chief guest. A floral welcome was accorded to her. A colorful cultural programme comprising of folk dances, folk songs, bhand and gidha was presented by the students of the college and Sikh Girls Senior Secondary School, Sidhwan Khurd. The energetic performance by the students mesmerized the audience. Dr. Amandeep Kaur congratulated all on this auspicious occasion. Sharing the traditional significance of this festival she told that conventionally the month of 'savan' and the Teej festival was a happy occasion for women when they used to visit their parent's home and celebrated this joyous time by assembling together, interacting with childhood friends and dancing and singing. She praised the performance of the students and lauded the efforts of the cultural committee which organized this function at a short notice. She expressed her joy and satisfaction that the students through their participation in myriad items have proved that they are closely connected to their roots and heritage. Mrs. Jatinder Kaur Principal (off.) and senior teacher Mrs. Kamaldeep Kaur from Sikh Girls Senior Secondary School graced the occasion as guests of honour. Faculty from GHG Harpakash College of Education and Sikh Girls Senior Secondary School also attended the event. Dr. Gagandeep Dharni proposed the formal vote of thanks and Ms. Inderjit Kaur conducted the stage effectively. The atmosphere was filled with fun and frolic when faculty and students danced to the tunes of traditional songs. Stalls of various eatables, nail-art and Mehndi were put up by the students under the guidance of incharge teachers for enhancing entrepreneurship skills





## ‘ਤੀਆਂ ਤੀਜ ਦੀਆਂ ਸਮਾਗਮ ਕਰਵਾਇਆ’



ਵਿਦਿਆਰਥਣਾਂ ਤੇ ਸਟਾਫ ਨੂੰ ਜਾਣਕਾਰੀ ਦਿੰਦੇ ਪ੍ਰਿੰਸੀਪਲ ਡਾ. ਅਮਨਦੀਪ ਕੌਰ। (ਮਾਨਵ)

ਜਗਰਾਓ, 17 ਅਗਸਤ (ਮਾਲਵਾ)-  
ਖਾਲਸਾ ਕਾਲਜ ਫਾਰ ਵੂਮੈਨ ਸਿੱਧਵਾਂ ਖੁਰਦ ਵਿਖੇ ਕਾਲਜ ਦੇ ਪ੍ਰਿੰਸੀਪਲ ਡਾ. ਅਮਨਦੀਪ ਕੌਰ (ਐਡੀਸ਼ਨਲ ਚਾਰਜ) ਦੀ ਯੋਗ ਅਗਵਾਈ 'ਚ ਤੀਆਂ ਤੀਜ ਦੀਆਂ ਸਮਾਗਮ ਆਯੋਜਿਤ ਕੀਤਾ ਗਿਆ। ਇਸ ਮੌਕੇ ਪ੍ਰਿੰਸੀਪਲ ਨੇ ਸਿੱਖ ਗਰਲਜ਼ ਸੀਨੀਅਰ ਸੈਕੰਡਰੀ ਸਕੂਲ ਦੇ ਪ੍ਰਿੰਸੀਪਲ ਜਤਿੰਦਰ ਕੌਰ, ਕਮਲਜੀਤ ਕੌਰ, ਜੀ. ਐੱਚ. ਜੀ. ਹਰਿਪ੍ਰਕਾਸ਼ ਕਾਲਜ ਆਫ ਐਜੂਕੇਸ਼ਨ ਤੋਂ ਪਹੁੰਚੇ ਸਟਾਫ ਮੈਂਬਰਾਂ ਦਾ ਭਾਵੁਕ ਸ਼ਲੀ ਵਿਚ ਨਿੱਘਾ ਸਵਾਗਤ ਕੀਤਾ। ਖਾਲਸਾ ਕਾਲਜ ਅਤੇ ਸਿੱਖ ਗਰਲਜ਼ ਸੀਨੀਅਰ ਸੈਕੰਡਰੀ ਸਕੂਲ ਦੀਆਂ ਵਿਦਿਆਰਥਣਾਂ ਨੇ ਸੱਭਿਆਚਾਰਕ ਵੰਨਗੀਆਂ ਗਰੁੱਪ ਡਾਂਸ, ਗੀਤ, ਭੰਡ ਅਤੇ ਗਿੱਧੇ ਰਾਹੀਂ ਆਪਣੀ ਕਲਾ ਦਾ ਪ੍ਰਦਰਸ਼ਨ ਕੀਤਾ।

ਇਸ ਸਮੇਂ ਵਿਦਿਆਰਥਣਾਂ ਨੇ ਹੱਥੀ ਕਿਰਤ ਅਤੇ ਆਮਦਨ ਪ੍ਰਾਪਤੀ ਦੇ

ਵਸੀਲਿਆਂ ਨੂੰ ਤਰਜੀਹ ਦਿੰਦਿਆਂ ਮਹਿੰਦੀ, ਨੇਲ ਆਰਟ, ਨਿੱਬੂ ਪਾਣੀ ਆਦਿ ਵੱਖ-ਵੱਖ ਸਟਾਲ ਵੀ ਲਾਏ। ਪ੍ਰਿੰਸੀਪਲ ਨੇ ਵਿਦਿਆਰਥਣਾਂ ਨੂੰ ਮੁਖਾਤਿਬ ਹੁੰਦਿਆਂ ਤੀਆਂ ਦੇ ਤਿਉਹਾਰ ਦੀ ਮਹੱਤਤਾ, ਧੀਆਂ ਤੇ ਨੂੰਹਾਂ ਦੁਆਰਾ ਦਿਲ ਦੇ ਭਾਵਾਂ ਨੂੰ ਉਭਾਰਨ ਆਦਿ ਪੱਖਾਂ ਨੂੰ ਸਾਂਝਾ ਕਰਦਿਆਂ ਕਾਲਜ ਦੀਆਂ ਵਿਦਿਆਰਥਣਾਂ ਦੁਆਰਾ ਵਿਭਿੰਨ ਵੰਨਗੀਆਂ ਰਾਹੀਂ ਕਲਾ ਦਾ ਪ੍ਰਦਰਸ਼ਨ ਕਰਦਿਆਂ ਮਾਹੌਲ ਨੂੰ ਰੋਣਕ ਬਣਾਉਣ ਲਈ ਵਧਾਈ ਦਿੱਤੀ। ਉਨ੍ਹਾਂ ਭਵਿੱਖ 'ਚ ਹੋਰ ਵੀ ਸੁਨਿਹਰੀ ਮੌਕਿਆਂ ਰਾਹੀਂ ਆਪਣੇ ਹੁਨਰ ਨੂੰ ਉਭਾਰਨ ਲਈ ਪ੍ਰੇਰਿਤ ਕੀਤਾ। ਉਨ੍ਹਾਂ ਸੱਭਿਆਚਾਰਕ ਕਮੇਟੀ ਦੀ ਬਹੁਤ ਬੇੜ੍ਹੇ ਸਮੇਂ ਦੌਰਾਨ ਸੁਚੱਜੇ ਢੰਗ ਨਾਲ ਪ੍ਰੋਗਰਾਮ ਆਯੋਜਿਤ ਕਰਨ ਲਈ ਖਲਾਅ ਕੀਤੀ। ਸਕੂਲ ਅਤੇ ਕਾਲਜ ਦੀਆਂ ਵਿਦਿਆਰਥਣਾਂ ਦੀ ਭਰਵੀਂ ਹਾਜ਼ਰੀ ਰਾਹੀਂ ਪ੍ਰੋਗਰਾਮ ਸਫਲਤਾਪੂਰਵਕ ਸੰਪੰਨ ਹੋਇਆ।



## Title: Lohri celebration at College

The traditional festival of Lohri was celebrated at Khalsa College for Women, Sidhwan Khurd under the able guidance of the Principal (Addl. Charge), Dr. Amandeep Kaur. The staff and students celebrated the occasion by customary ritual of offering 'til' in the bonfire. The atmosphere was enlivened with festive fervour, when student Manpreet Kaur recited a poem dedicated to the event, Garima presented an energetic dance and Muskan Kaur and her fellow classmates mesmerized the audience with their group dance. Students of Sikh Girls Senior Secondary School, Sidhwan Khurd also attended the event and showcased their talent through poetical recitation. Dr. Amandeep Kaur congratulated Gurnaz Kaur **daughter** of Prof. Harwinder Kaur, Kafia Brar **daughter** of Prof. Ramanpreet Kaur, Mehtab Singh son of Prof. Harmanpreet Kaur and Gurneev Kaur **daughter** of Dr. Paramdeep Singh on this auspicious day of their **first Lohri**. Best wishes were conveyed to the newly wed staff members. Gurjit Singh, Prof. Sumit Kumar and S. Jagraj Singh who were celebrating their first Lohri. Groundnuts and Rewari were distributed to all. Tea Party was arranged for staff. Dr. Gagandeep Dharni and Dr. Inderjit Kaur incharges of the function conducted the proceedings effectively.





# ਖ਼ਾਲਸਾ ਕਾਲਜ ਫ਼ਾਰ ਵਿਮੈਨ ਸਿੱਧਵਾਂ ਖੁਰਦ ਵਿਖੇ ਲੋਹੜੀ ਸਮਾਗਮ

ਚੌਕੀਮਾਨ, 13 ਜਨਵਰੀ (ਤੇਜਿੰਦਰ ਸਿੰਘ ਚੌਢਾ)-ਸ੍ਰੀ ਗੁਰੂ ਹਰਿਗੋਬਿੰਦ ਉਜਾਗਰ ਹਰੀ ਟਰੱਸਟ-ਸਿੱਧਵਾਂ ਖੁਰਦ ਦੀ ਸਿਰਮੌਰ ਸੰਸਥਾ ਖ਼ਾਲਸਾ ਕਾਲਜ ਫ਼ਾਰ ਵਿਮੈਨ ਸਿੱਧਵਾਂ ਖੁਰਦ ਦੇ ਪ੍ਰਿੰਸੀਪਲ ਡਾ. ਅਮਨਦੀਪ ਕੌਰ (ਐਡੀਸ਼ਨਲ ਚਾਰਜ) ਦੀ ਯੋਗ ਅਗਵਾਈ ਹੇਠ ਲੋਹੜੀ ਸਮਾਗਮ ਆਯੋਜਿਤ ਕੀਤਾ ਗਿਆ। ਡਾ. ਗਗਨਦੀਪ ਧਾਰਨੀ ਨੇ ਪ੍ਰਿੰਸੀਪਲ ਡਾ. ਅਮਨਦੀਪ ਕੌਰ ਨੂੰ ਨਿੱਘੀ ਜੀ ਆਇਆਂ ਕਿਹਾ। ਇਸ ਸ਼ੁੱਭ ਤਿਉਹਾਰ ਦੇ ਮੌਕੇ ਪ੍ਰਿੰਸੀਪਲ ਡਾ. ਅਮਨਦੀਪ ਕੌਰ ਅਤੇ ਸਮੂਹ ਸਟਾਫ਼ ਨੇ ਸਮੂਹਿਕ ਰੂਪ ਵਿਚ ਪੂਣੀ ਬਾਲ ਕੇ ਤਿਲ ਅਰਪਣ ਕੀਤੇ। ਪ੍ਰਿੰਸੀਪਲ ਡਾ. ਅਮਨਦੀਪ ਕੌਰ ਨੇ ਲੋਹੜੀ ਦੇ ਤਿਉਹਾਰ ਦੀਆਂ ਮੁਬਾਰਕਾਂ ਦਿੰਦਿਆਂ ਨਵ-ਵਿਆਹੇ ਸਟਾਫ਼ ਮੈਂਬਰਾਂ ਅਤੇ ਨਵ-ਜੰਮੇ ਬੱਚਿਆਂ ਦੀ ਪਹਿਲੀ ਲੋਹੜੀ ਦੀ ਵਧਾਈ ਦਿੱਤੀ। ਜ਼ਿਕਰਯੋਗ ਹੈ ਕਿ ਇਸ ਵਰ੍ਹੇ ਸਟਾਫ਼ ਵਿਚ ਚਾਰ ਬੱਚੇ ਜਿੰਨ੍ਹਾਂ ਵਿਚ ਪ੍ਰੋ. ਹਰਵਿੰਦਰ ਕੌਰ ਦੀ ਬੇਟੀ ਗੁਰਬਾਜ਼ ਕੌਰ, ਪ੍ਰੋ. ਰਮਨਪ੍ਰੀਤ ਕੌਰ ਦੀ ਬੇਟੀ ਕਾਫ਼ੀਆ ਬਰਾੜ, ਡਾ. ਪਰਮਦੀਪ ਸਿੰਘ ਦੀ ਬੇਟੀ ਗਨੀਵ ਕੌਰ ਅਤੇ ਪ੍ਰੋ. ਹਰਮਨਪ੍ਰੀਤ ਕੌਰ ਦੇ ਬੇਟੇ ਮਹਿਤਾਬ ਸਿੰਘ

ਦੀ ਪਹਿਲੀ ਲੋਹੜੀ ਮਨਾਈ ਗਈ। ਪ੍ਰੋ. ਗੁਰਜੀਤ ਸਿੰਘ, ਪ੍ਰੋ. ਸੁਮੀਤ ਕੁਮਾਰ ਅਤੇ

ਪ੍ਰਿੰਸੀਪਲ ਡਾ. ਅਮਨਦੀਪ ਕੌਰ ਨੇ ਸਮੂਹ ਸਟਾਫ਼ ਅਤੇ ਵਿਦਿਆਰਥੀਆਂ ਨੂੰ ਮੁੰਗਫਲੀ



ਖ਼ਾਲਸਾ ਕਾਲਜ ਫ਼ਾਰ ਵਿਮੈਨ ਸਿੱਧਵਾਂ ਖੁਰਦ ਵਿਖੇ ਲੋਹੜੀ ਦਾ ਤਿਉਹਾਰ ਮਨਾਉਣ ਸਮੇਂ ਪੂਣੀ ਬਾਲਦੇ ਹੋਏ ਕਾਲਜ ਦੇ ਪ੍ਰਿੰਸੀਪਲ ਡਾ. ਅਮਨਦੀਪ ਕੌਰ ਨਾਲ ਕਾਲਜ ਅਧਿਆਪਕ।  
ਤਸਵੀਰ: ਤੇਜਿੰਦਰ ਸਿੰਘ ਚੌਢਾ

ਜਗਰਾਜ ਸਿੰਘ ਦੇ ਵਿਆਹ ਦੀ ਖੁਸ਼ੀ ਨੂੰ ਵੀ ਇਸ ਮੌਕੇ ਸਾਂਝਾ ਕੀਤਾ ਗਿਆ। ਸਮਾਗਮ ਦੀ ਸ਼ੁਰੂਆਤ ਵਿਚ ਵਿਦਿਆਰਥਣ ਮਨਪ੍ਰੀਤ ਕੌਰ ਨੇ ਕਵਿਤਾ ਗਾਇਨ ਕੀਤੀ। ਸਿੱਖ ਗਰਲਜ਼ ਸੀਨੀਅਰ ਸੈਕੰਡਰੀ ਸਕੂਲ ਦੀਆਂ ਵਿਦਿਆਰਥਣਾਂ ਨੇ ਵੀ ਕਵਿਤਾਵਾਂ ਪੌੜ ਕੀਤੀਆਂ।

ਅਤੇ ਰਿਉੜੀਆਂ ਵੰਡ ਕੇ ਖੁਸ਼ੀ ਦਾ ਇਜ਼ਹਾਰ ਕੀਤਾ। ਸਟਾਫ਼ ਲਈ ਚਾਹ ਪਾਰਟੀ ਦਾ ਆਯੋਜਨ ਕੀਤਾ ਗਿਆ। ਸਮਾਗਮ ਦੇ ਇੰਚਾਰਜ ਡਾ. ਗਗਨਦੀਪ ਧਾਰਨੀ ਹਨ ਅਤੇ ਮੰਚ ਸੰਚਾਲਕ ਦੀ ਭੂਮਿਕਾ ਡਾ. ਇੰਦਰਜੀਤ ਕੌਰ ਦੁਆਰਾ ਬਾਖ਼ੂਬੀ ਨਿਭਾਈ ਗਈ।

## **PG Department of Punjabi, Khalsa College for Women and GHG Harparkash College of Education, Sidhwan Khurd jointly organize One Day International Seminar.**

Under the aegis of SGHGU Hari Trust and able guidance of Dr. Amandeep Kaur, Principal, Khalsa College for Women, Sidhwan Khurd, the PG Department of Punjabi of the College and GHG Harparkash College of Education, Sidhwan Khurd jointly organized one day international seminar titled “Punjabi Sahit de Vikas vich Nari Sahitkaran di Bhumika.” The event was organized in collaboration with Punjabi Sahit Academy, Chandigarh and Jagat Punjabi Sahit Academy, Canada. S. Ajaib Singh Chattha, Chairman, Jagat Punjabi Sabha Canada was the esteemed chief guest. Dr. Amandeep Kaur delivered the formal welcome address and greeted the luminaries and delegates. In the inaugural session, Dr. Inderjit Kaur, HOD, PG Department of Punjabi of the College and Co-convenor of the Seminar presented an overview of the theme and conducted the proceedings. Dr. Sarabjit Kaur Sohal, President, Punjabi Sahit Sabha, Chandigarh graced the occasion and presided over as Chairperson. She stressed on the need to reflect upon the fundamental changes in literature by women observed through the passage of time and creation of awareness on women related issues. In his keynote address Dr. Satnam Singh Jassal, Dean, Guru Kashi University, Talwandi Sabo, Bathinda enlightened the audience on the role played by women in the generation of various social aspects, and the subsequent degradation in the status of women in patriarchal society as compared to a high place accorded to her in the tribal groups. Chief guest S. Ajaib Singh Chattha, addressed the audience and said that a woman plays the most significant and humane role in familial relations. S. Arvinder Singh Dhillon, Coordinator, Jagat Punjabi Sabha (India) who was the guest of honour spoke on the occasion and highlighted the contribution of Punjabi women writers, Dr. Dalip Kaur Tiwana and Amrita Pritam in portraying contemporary situation of women. He lauded the magazine “Nagmani” for giving opportunity to women editors. The first technical session was chaired by Dr. Raminder Kaur, formerly Dean, Guru Nanak Dev University, Amritsar. Dr. Jagminder Kaur from Punjabi Department, GHG Harparkash College of Education, Sidhwan Khurd conducted the session. Delegates Dr. Gurcharan Kaur Kochar, Dr. Gurpreet Kaur Brar, Dr. Pushwinder Kaur Khokhar and Dr. Inderjit Kaur explored the myriad aspects of the topic through their paper presentations. In the second technical session Dr. Satnam Singh Jassal was the chairperson. Delegates Dr. Jagjit Singh, Dr. Amaninderpreet Chahal, Dr. Simarjit Gill, Dr. Gurpreet Singh, Dr. Sona, Dr. Satpreet Singh and S. Harjinder Singh presented papers reflecting on the theme of the seminar from varied perspectives. Third technical session was conducted in online mode and was chaired by S. Ajaib Singh Chattha. Dr. Gurwinder Singh from Punjabi Department of GHG Harparkash College of Education, Sidhwan Khurd conducted the session and 19 delegates presented their papers. Book titled “Ravinder Ravi de Kav Natak (Samajwadi Drishti ton)” authored by Dr. Inderjit Kaur was released on the event and she was felicitated by Jagat Punjabi Sabha, Canada. S. Harmail Singh Sidhu, worthy senior member of SGHGU Hari Trust made the occasion more special by his presence and accompanied the Principal in honouring the distinguished guests with mementos and shawls. Dr. Shveta Dhand, officiating Principal, GHG Institute of Law attended the programme. Dr. Amandeep Kaur proposed formal vote of thanks.





## ‘ਪੰਜਾਬੀ ਸਾਹਿਤ ਦੇ ਵਿਕਾਸ ‘ਚ ਨਾਰੀ ਸਾਹਿਤਕਾਰਾਂ ਦੀ ਭੂਮਿਕਾ’ ਵਿਸ਼ੇ ‘ਤੇ ਅੰਤਰਰਾਸ਼ਟਰੀ ਸੈਮੀਨਾਰ ਆਯੋਜਿਤ

ਜਗਰਾਹਿ, 6 ਫਰਵਰੀ (ਮਾਨਵਾ)-ਖਾਲਸਾ ਕਾਲਜ ਫਾਰ ਯੂਮੈਨ ਅਤੇ ਜੀ ਐੱਚ. ਜੀ ਹਰਿਪ੍ਰਕਾਸ਼ ਕਾਲਜ ਫਾਰ ਯੂਮੈਨ ਸਿੱਖਵਾ ਖੁਰਦ ਦੁਆਰਾ ਸਾਂਝੇ ਰੂਪ ਵਿਚ ਇਕ ਹੋਰ ਅੰਤਰਰਾਸ਼ਟਰੀ ਸੈਮੀਨਾਰ ਆਯੋਜਿਤ ਕੀਤਾ ਗਿਆ। ਪੇਸਟ ਐਜੂਕੇਟ ਪੰਜਾਬੀ ਵਿਭਾਗ ਵਲੋਂ ਪੰਜਾਬੀ ਸਾਹਿਤ ਅਕਾਦਮੀ ਚੰਡੀਗੜ੍ਹ ਅਤੇ ਜਗਤ ਪੰਜਾਬੀ ਸਭਾ, ਕੈਨੇਡਾ ਦੇ ਸਹਿਯੋਗ ਨਾਲ ‘ਪੰਜਾਬੀ ਸਾਹਿਤ ਦੇ ਵਿਕਾਸ ਵਿਚ ਨਾਰੀ ਸਾਹਿਤਕਾਰਾਂ ਦੀ ਭੂਮਿਕਾ ਵਿਸ਼ੇ ‘ਤੇ ਅੰਤਰ-ਰਾਸ਼ਟਰੀ ਸੈਮੀਨਾਰ ਕਰਵਾਇਆ ਗਿਆ।

ਸੰਸਥਾ ਦੇ ਪਿੰਜੋਪਲ ਅਤੇ ਕਨਵੀਨਰ ਡਾ. ਅਨਦੀਪ ਕੌਰ ਨੇ ਸੈਮੀਨਾਰ ਵਿਚ ਪਹੁੰਚੇ ਸਾਰੇ ਮਹਿਮਾਨਾਂ ਨੂੰ ਜੀ ਆਇਆ ਕਿਹਾ। ਸੈਮੀਨਾਰ ਦੇ ਕੋ-ਕਨਵੀਨਰ ਡਾ. ਇੰਦਰਜੀਤ ਕੌਰ ਨੇ ਸਟੇਜ ਸਕੱਤਰ ਦੀ ਭੂਮਿਕਾ ਨਿਭਾਉਂਦਿਆਂ ਸੈਮੀਨਾਰ ਦੀ ਰੂਪ-ਰੇਖਾ ਬਾਰੇ ਜਾਣਕਾਰੀ ਦਿੱਤੀ। ਸਮਾਗਮ ਦੀ ਸ਼ੁਰੂਆਤ ਬਬਰ ਗਾਇਨ ਨਾਲ ਹੋਈ। ਮੁੱਖ ਸੁਰ ਡਾਬਟ ਵਕਤਾ ਡਾ. ਸਤਨਾਮ ਸਿੰਘ ਜੋਸਲ, ਡੀਨ, ਗੁਰੂ ਕਾਬੀ ਯੂਨੀਵਰਸਿਟੀ, ਤਲਵੰਡੀ ਸਾਬੋ (ਬਠਿੰਡਾ) ਨੇ ਮੁਖਾਬਤ ਹੁੰਦਿਆਂ ਕਿਹਾ ਕਿ ਨਾਰੀ, ਮਾਨਵ ਜਾਤ ਦੀ ਭੂਮਿਕਾ ਨਿਰਜਕ, ਸਮਾਜ-ਸਭਿਆਚਾਰਕ ਵਿਚ ਨਾਰੀ ਦੀ ਸਥਿਤੀ, ਕਬੀਲਾ ਸਮਾਜ ਵਿਚ ਨਾਰੀ ਦੀ ਉੱਚਤਾ, ਪੰਜੀਵਾਲੀ ਸਮਾਜ ਵਿਚ ਨਾਰੀ ਦੀ ਸਥਿਤੀ



ਸਨਮਾਨਿਤ ਬਰਨ ਮੋਕੇ ਕਾਲਜ ਦੇ ਪ੍ਰਬੰਧਕ ਤੇ ਸਟਾਫ਼ (ਮਾਨਵਾ)

ਵਿਚ ਗਿਰਾਵਟ ਆਦਿ ਪੇਖਾਂ ਨੂੰ ਸਾਝਾ ਕੀਤਾ।

ਸੈਮੀਨਾਰ ਦੀ ਪ੍ਰਧਾਨਗੀ ਡਾ. ਸਰਬਜੀਤ ਕੌਰ ਸੋਹਲ, ਪ੍ਰਧਾਨ, ਪੰਜਾਬ ਸਾਹਿਤ ਅਕਾਦਮੀ ਚੰਡੀਗੜ੍ਹ ਦੁਆਰਾ ਕੀਤੀ ਗਈ। ਉਨ੍ਹਾਂ ਪੰਜਾਬੀ ਸਾਹਿਤ ਵਿਚ ਨਾਰੀ ਸਾਹਿਤਕਾਰਾਂ ਦੀ ਭੂਮਿਕਾ ਵਿਸ਼ੇ ‘ਤੇ ਚਿਰਕ ਕਰਦਿਆਂ ਅਜੋਕੇ ਨਾਰੀ ਸਾਹਿਤ ਵਿਚ ਭੁਨਿਆਈ ਤਬਦੀਲੀਆਂ, ਵਿਭਿੰਨ ਵਿਚ ਚਿੰਤਨ ਸਬੰਧੀ ਜਾਗਰੂਕਤਾ, ਅਜੋਕੇ ਦੌਰ ਵਿੱਚ ਨਾਰੀ ਸਵੈ ਚਿੰਤਨ ਦੀ ਲੋੜ ਆਦਿ ਵਿਭਿੰਨ ਨੂੰ ਸਾਝਾ ਕੀਤਾ। ਇਸ ਮੌਕੇ ਅਜੋਬ ਸਿੰਘ ਚੌਠਾ, ਚੇਅਰਮੈਨ, ਜਗਤ ਪੰਜਾਬੀ ਸਭਾ, ਕੈਨੇਡਾ ਨੇ ਔਰਤ-ਮਰਦ ਦੇ ਰਿਸ਼ਤੇ

ਬਾਰੇ ਚਿਰਕ ਕਰਦਿਆਂ ਪਰਿਵਾਰਕ ਜੀਵਨ ਵਿਚ ਔਰਤ ਦੀ ਹੋਂਦ, ਉੱਚਤਾ ਅਤੇ ਪ੍ਰਮੁੱਖਤਾ ਨੂੰ ਵਿਚਾਰ ਅਧੀਨ ਲਿਆਂਦਾ। ਇਸ ਮੌਕੇ ਵਿਸ਼ੇਸ਼ ਮਹਿਮਾਨ ਅਰਵਿੰਦਰ ਸਿੰਘ ਢਿਲੋਂ, ਕੰਔਰਡੀਨੇਟਰ, ਜਗਤ ਪੰਜਾਬੀ ਸਭਾ (ਭਾਰਤ) ਨੇ ਅੰਤਿਮ ਪ੍ਰੀਤਮ ਅਤੇ ਦਲੀਪ ਕੌਰ ਟਿਵਾਣਾ ਦੀਆਂ ਲਿਖਤਾਂ ਰਾਹੀਂ ਨਾਰੀ ਦੀ ਮੁੱਢਲੀ ਅਤੇ ਅਸਲ ਤਸਵੀਰ ਨੂੰ ਦ੍ਰਿਸ਼ਟੀਗੋਚਰ ਕੀਤਾ। ਪਹਿਲੇ ਤਕਨੀਕੀ ਸੈਸ਼ਨ ਦੀ ਪ੍ਰਧਾਨਗੀ ਡਾ. ਰਮਿੰਦਰ ਕੌਰ, ਸਾਬਕਾ ਡੀਨ, ਗੁਰੂ ਨਾਨਕ ਦੇਵ ਯੂਨੀਵਰਸਿਟੀ, ਅੰਮ੍ਰਿਤਸਰ ਦੁਆਰਾ ਕੀਤੀ ਗਈ। ਇਸ ਮੌਕੇ ਡਾ. ਗੁਰਚਰਨ ਕੌਰ ਕੰਚਰ, ਡਾ. ਗੁਰਪ੍ਰੀਤ ਕੌਰ

ਬਰਾੜ ਅਤੇ ਡਾ. ਪੁਸ਼ਪਿੰਦਰ ਕੌਰ ਖੇਖਰ ਦੁਆਰਾ ਨਾਰੀ ਸੇਵੇਦਨਾ ਵਿਸ਼ੇ ‘ਤੇ ਆਪਣੇ ਖੋਜ ਪੱਤਰ ਪ੍ਰਸਤੁਤ ਕੀਤੇ। ਦੂਸਰੇ ਤਕਨੀਕੀ ਸੈਸ਼ਨ ਦੀ ਪ੍ਰਧਾਨਗੀ ਡਾ. ਸਤਨਾਮ ਸਿੰਘ ਜੋਸਲ ਦੁਆਰਾ ਕੀਤੀ ਗਈ ਜਿਸ ਵਿੱਚ ਡਾ. ਜਗਜੀਤ ਸਿੰਘ, ਡਾ. ਅਮਨਿੰਦਰਪ੍ਰੀਤ ਚਹਿਲ, ਡਾ. ਸਿਮਰਜੀਤ ਗਿੱਲ, ਡਾ. ਗੁਰਪ੍ਰੀਤ ਸਿੰਘ, ਡਾ. ਸੋਨਾ, ਡਾ. ਸਤਪ੍ਰੀਤ ਸਿੰਘ ਅਤੇ ਹਰਜਿੰਦਰ ਸਿੰਘ ਨੇ ਖੋਜ ਪੱਤਰ ਪ੍ਰਸਤੁਤ ਕੀਤੇ। ਆਨਲਾਈਨ ਸੈਸ਼ਨ ਵਿਚ ਕੁੱਲ 19 ਪੰਜਾਬੀਆਂ ਨੇ ਖੋਜ ਪੱਤਰ ਪੇਸ਼ ਕੀਤੇ ਇਸ ਮੌਕੇ ਸ੍ਰੀ ਗੁਰੂ ਹਰਿਗੋਬਿੰਦ ਉਜਾਗਰ ਹਰੀ ਟਰੱਸਟ ਸਿੱਖਵਾ ਖੁਰਦ ਦੇ ਸੀਨੀਅਰ ਮੈਂਬਰ ਹਰਮਲ ਸਿੰਘ, ਪਿੰਜੋਪਲ ਡਾ. ਸ਼ਬੇਤਾ ਓਬ, ਪਿੰਜੋਪਲ ਦਲਜੀਤ ਕੌਰ ਨੇ ਵਿਸ਼ੇਸ਼ ਤੌਰ ਤੇ ਸ਼ਿਰਕਤ ਕੀਤੀ। ਹਰਮਲ ਸਿੰਘ ਨੇ ਸਮੂਹ ਮਹਿਮਾਨਾਂ ਦਾ ਧੰਨਵਾਦ ਪ੍ਰਗਟ ਕੀਤਾ।

ਸੈਮੀਨਾਰ ਦੇ ਕੋ-ਕਨਵੀਨਰ ਡਾ. ਗੁਰਵਿੰਦਰ ਸਿੰਘ ਨੇ ਸਾਰੇ ਮਹਿਮਾਨਾਂ ਦਾ ਰਸਮੀ ਤੌਰ ਤੇ ਧੰਨਵਾਦ ਕੀਤਾ ਇਸ ਮੌਕੇ ਡਾ. ਇੰਦਰਜੀਤ ਕੌਰ ਦੀ ਖੋਜ ਪ੍ਰਸਤੁਤ ‘ਹਰਿੰਦਰ ਰਵੀ ਦੇ ਕਾਵਿ-ਨਾਟਕ’ ਦਾ ਸਮਾਜਵਾਦੀ ਦ੍ਰਿਸ਼ਟੀਕੋਣ’ ਰਿਲੀਜ਼ ਕੀਤੀ ਗਈ। ਇਸ ਮੌਕੇ ਟਰੱਸਟ ਮੈਂਬਰ ਅਤੇ ਪਿੰਜੋਪਲ ਵੱਲੋਂ ਸਮੂਹ ਮਹਿਮਾਨਾਂ ਨੂੰ ਸਨਮਾਨ ਚਿੰਨ੍ਹ ਨਾਲ ਨਵਾਜਿਆ ਗਿਆ।



## **International women's day observed at Khalsa College for Women, Sidhwan Khurd**

Under the able guidance of Principal, [Addl. Charge] Dr. Amandeep Kaur, Red Ribbon Club and PG department of History of Khalsa College for Women Sidhwan Khurd celebrated International Women's Day. On this occasion, an Essay writing competition on the theme 'Female Foeticide/Save Girl Child' was organized. Total 25 students participated in this competition. Winners were awarded with cash prizes and all the participants were given Appreciation certificates. Hansika of [B.Com](#) Ist bagged first prize of Rs. 700, Muskan of B.A.IInd bagged second prize of Rs. 500, Garima of [B.Com](#) Ist bagged third prize of Rs.300 and Consolation prize was grabbed by Subhangi of B. Sc. IInd. The college principal lauded the efforts of students. She also motivated students to act as social messengers and spread awareness among all. She concluded by saying, "Here's to the women who are breaking barriers, challenging norms, and making the world a better place. Your resilience is truly inspiring."





ਖ਼ਾਲਸਾ ਕਾਲਜ ਫ਼ਾਰ ਵਿਮੈਨ ਸਿੱਧਵਾਂ ਖ਼ੁਰਦ ਵਿਖੇ ਕਰਵਾਏ ਮੁਕਾਬਲਿਆਂ ਵਿਚ ਜੇਤੂ ਰਹੀਆਂ ਵਿਦਿਆਰਥਣਾਂ ਦੀਆਂ ਤਸਵੀਰਾਂ।

## ਖ਼ਾਲਸਾ ਕਾਲਜ ਵਿਖੇ ਅੰਤਰਰਾਸ਼ਟਰੀ ਨਾਰੀ ਦਿਵਸ ਨੂੰ ਸਮਰਪਿਤ ਲੇਖ ਲਿਖਣ ਮੁਕਾਬਲਾ ਕਰਵਾਇਆ

ਚੌਕੀਮਾਨ, 9 ਮਾਰਚ (ਤੇਜਿੰਦਰ ਸਿੰਘ ਚੌਢਾ)-ਖ਼ਾਲਸਾ ਕਾਲਜ ਫ਼ਾਰ ਵਿਮੈਨ ਸਿੱਧਵਾਂ ਖ਼ੁਰਦ ਵਿਖੇ ਪ੍ਰਿੰਸੀਪਲ ਡਾ. ਅਮਨਦੀਪ ਕੌਰ (ਐਡੀਸ਼ਨਲ ਚਾਰਜ) ਦੀ ਯੋਗ ਅਗਵਾਈ ਹੇਠ ਰੈੱਡ ਰਿੱਬਨ ਕਲੱਬ ਅਤੇ ਪੀ.ਜੀ. ਇਤਿਹਾਸ ਵਿਭਾਗ ਵਲੋਂ ਅੰਤਰ ਰਾਸ਼ਟਰੀ ਨਾਰੀ ਦਿਵਸ ਨੂੰ ਸਮਰਪਿਤ, ਭਰੂਣ ਹੱਤਿਆ ਅਤੇ ਬੇਟੀ ਬਚਾਉ ਵਿਸ਼ਿਆਂ ਤੇ ਲੇਖ ਲਿਖਣ ਮੁਕਾਬਲਾ ਕਰਵਾਇਆ ਗਿਆ। ਇਸ ਮੁਕਾਬਲੇ ਵਿਚ 25 ਵਿਦਿਆਰਥਣਾਂ ਨੇ ਭਾਗ ਲਿਆ, ਜਿਸ ਵਿਚ ਜੇਤੂ ਰਹੀਆਂ ਵਿਦਿਆਰਥਣਾਂ ਨੂੰ ਨਕਦ ਇਨਾਮ ਅਤੇ ਭਾਗ ਲੈਣ

ਵਾਲੀਆਂ ਵਿਦਿਆਰਥਣਾਂ ਨੂੰ ਸਰਟੀਫਿਕੇਟ ਤਕਸੀਮ ਕੀਤੇ ਗਏ। ਬੀ.ਕਾਮ ਭਾਗ ਪਹਿਲੇ ਦੀ ਹੰਸਿਕਾ ਨੇ 700 ਰੁਪਏ ਦਾ ਪਹਿਲਾ ਇਨਾਮ, ਬੀ.ਏ. ਭਾਗ ਦੂਜਾ ਦੀ ਮੁਸਕਾਨ ਕੌਰ ਨੇ 500 ਰੁਪਏ ਦਾ ਦੂਜਾ ਇਨਾਮ, ਬੀ.ਕਾਮ ਪਹਿਲਾ ਦੀ ਗਰਿਮਾ ਨੇ 300 ਰੁਪਏ ਦਾ ਤੀਜਾ ਇਨਾਮ ਅਤੇ ਬੀ.ਐੱਸ.ਸੀ. ਭਾਗ ਦੂਜਾ ਦੀ ਸੁਭਾਂਗੀ ਨੇ ਹੌਸਲਾ ਅਫਜਾਈ ਇਨਾਮ ਹਾਸਲ ਕੀਤਾ। ਪ੍ਰਿੰਸੀਪਲ ਡਾ. ਅਮਨਦੀਪ ਕੌਰ ਨੇ ਵਿਦਿਆਰਥਣਾਂ ਦੀ ਭਰੂਣ ਹੱਤਿਆ ਤੇ ਬੇਟੀ ਬਚਾਉ ਦੇ ਪ੍ਰਤੀ ਜਾਗਰੂਕਤਾ ਦੇ ਲਈ ਕੀਤੇ ਯਤਨਾਂ ਦੀ ਸ਼ਲਾਘਾ ਕੀਤੀ।



## An awareness programme on 'Female Hygiene'



An awareness programme on 'Female Hygiene' was organized by NSS Units at Khalsa College for Women, Sidhwan Khurd on **March 20, 2024**. Dr. Roohi Deol a specialist in gynaecology and obstetrics from Deol Hospital, Mullanpur was the resource person. Dr. Amandeep Kaur welcomed the esteemed guest and encouraged the students to benefit from the expert views shared by her. Floral saplings were presented to her and the team of experts accompanying her. Addressing the audience Dr. Roohi Deol stressed the importance of knowing ones blood group and how blood donation can help many people in need of different components of the blood. She said that young girls should maintain an optimum level of haemoglobin to lead a healthy life. She shared vital information on feminine hygiene during menstruation and asked the girls to adopt eco-friendly, sustainable and reusable options in place of synthetic sanitary pads. The superstitions and misconceptions about menstruation were also dispelled by her. A health checkup camp was organized by her team in which BMI, haemoglobin and blood group were tested. Dr. Roohi Deol was felicitated with a memento.

### ਖਾਲਸਾ ਕਾਲਜ 'ਚ ਸਿਹਤ ਜਾਂਚ ਕੈਂਪ ਲਾਇਆ

ਜਗਰਾਓ, 20 ਮਾਰਚ (ਮਾਲਵਾ) - ਖਾਲਸਾ ਕਾਲਜ ਡਾ. ਰੂਹੀ ਦੇਵਲ, ਸਿੱਧਵਾਂ ਖੁਰਦ ਦੇ ਪਿੰਸੀਪਲ ਡਾ. ਅਮਨਦੀਪ ਕੌਰ ਦੀ ਯੋਗ ਅਗਵਾਈ ਅਧੀਨ ਸੱਤ ਰੋਜ਼ਾ ਕੈਂਪ ਦੇ ਪੰਜਵੇਂ ਦਿਨ ਸਿਹਤ ਜਾਂਚ ਕੈਂਪ ਲਾਇਆ ਗਿਆ। ਇਸ ਵਿਚ ਡਾ. ਰੂਹੀ ਦੇਵਲ (ਦਿੱਲੀ ਹਸਪਤਾਲ, ਮੱਲਾਪੁਰ) ਨੇ ਮੁੱਖ ਮਹਿਮਾਨ ਵਜੋਂ ਸ਼ਿਰਕਤ ਕੀਤੀ।

ਪ੍ਰੋਗਰਾਮ ਅਫਸਰ ਡਾ. ਇੰਦਰਜੀਤ ਕੌਰ ਨੇ ਮੌਕਾ ਸੋਚਾਲਕ ਦੀ ਭੂਮਿਕਾ ਨਿਭਾਉਂਦਿਆਂ ਮੁੱਖ ਮਹਿਮਾਨ ਅਤੇ ਉਨ੍ਹਾਂ ਨਾਲ ਪਹੁੰਚੀ ਟੀਮ ਤੋਂ ਜਾਣੂੰ ਕਰਵਾਇਆ ਸ਼ੇਸਥਾ ਦੇ ਪਿੰਸੀਪਲ ਨੇ ਮੁੱਖ ਮਹਿਮਾਨ ਨੂੰ ਰਸਮੀ ਤੌਰ 'ਤੇ ਜੀ ਆਇਆ ਕਿਹਾ ਅਤੇ ਹੁਸ਼ਿਆਰੀ ਵਿਚ ਸਮਾਂ ਕੱਢਦਿਆਂ ਵਿਦਿਆਰਥਣਾਂ ਨੂੰ ਸਿਹਤ ਸਬੰਧੀ ਜਾਗਰੂਕ ਕਰਨ ਲਈ ਧੰਨਵਾਦ ਕੀਤਾ।

ਡਾ. ਰੂਹੀ ਨੇ ਵਿਦਿਆਰਥਣਾਂ ਨੂੰ ਮੁਖੀਅਤ ਹੁੰਦਿਆਂ ਉਮਰ ਦੇ ਅਨੁਸਾਰ ਕੱਚ, ਭਾਰ,



ਮੁੱਖ ਮਹਿਮਾਨ ਨੂੰ ਸਨਮਾਨਿਤ ਕਰਦੇ ਪਿੰਸੀਪਲ ਡਾ. ਅਮਨਦੀਪ ਕੌਰ ਤੇ ਹੋਰ। <<<

ਹਿਮੋਗਲੋਬਿਨ ਤੇ ਬਲੱਡ ਗਰੁੱਪ ਸਬੰਧੀ ਮਹੱਤਵਪੂਰਨ ਜਾਣਕਾਰੀ ਸਾਂਝੀ ਕੀਤੀ। ਉਨ੍ਹਾਂ ਨੇ ਅੰਗਰੇਜ਼ੀ ਦੇ ਵੱਖ-ਵੱਖ ਰੋਗਾਂ ਦੇ ਇਲਾਜ, ਮਹਾਵਾਰੀ ਦੇ ਦਿਨਾਂ ਵਿਚ ਉਚਿਤ ਸਫ਼ਾਈ ਰੱਖਣ, ਈਕੋ-ਫ਼ਰੈਂਡਲੀ ਵਸਤਾਂ ਦੀ ਵਰਤੋਂ, ਪੁਨਰ ਵਰਤੋਂ ਹਿੱਤ ਸੈਨਟਰੀ ਪੈਂਡ ਦੀ ਯੋਗ ਵਰਤੋਂ ਦੇ ਸੁਝਾਅ ਪ੍ਰਗਟ ਕੀਤੇ।

ਡਾ. ਇੰਦਰਜੀਤ ਕੌਰ ਨੇ ਡਾ. ਰੂਹੀ ਦਾ ਧੰਨਵਾਦ ਕੀਤਾ। ਸ਼ੇਸਥਾ ਵਲੋਂ ਮੁੱਖ ਮਹਿਮਾਨ ਨੂੰ ਸਨਮਾਨ ਚਿੰਨ੍ਹ ਅਤੇ ਪੂਰੀ ਟੀਮ ਨੂੰ ਫੁੱਟੇ ਦੇ ਕੇ ਨਿਵਾਜਿਆ ਗਿਆ। ਸਿਹਤ ਜਾਂਚ ਕੈਂਪ ਵਿਚ ਵਿਦਿਆਰਥਣਾਂ ਅਤੇ ਅਧਿਆਪਕਾਂ ਸਮੇਤ 111 ਮੈਂਬਰਾਂ ਨੇ ਆਪਣੀ ਸਿਹਤ ਜਾਂਚ ਦਾ ਲਾਭ ਲਿਆ।



# Scholarships and fee concessions

Our college provides **scholarships and fee concessions**; this initiative likely helps to promote accessibility to education and supports students facing financial challenge.

Prospectus 2023-24

## RULES OF LEAVING THE COLLEGE:

ਜਿਹੜੀ ਵਿਦਿਆਰਥਣ ਕਾਲਜ ਛੱਡਣਾ ਚਾਹੇ ਉਸ ਨੂੰ ਅਜਿਹਾ ਕਰਨ ਲਈ ਪ੍ਰਿੰਸੀਪਲ ਦੀ ਲਿਖਤੀ ਆਗਿਆ ਲੈਣੀ ਜ਼ਰੂਰੀ ਹੈ। ਅਜਿਹੀ ਅਰਜ਼ੀ ਤੇ ਵਿਦਿਆਰਥਣ ਦੇ ਪਿਤਾ/ਸਰਪ੍ਰਸਤ ਦੇ ਦਸਤਖਤ ਹੋਣੇ ਜ਼ਰੂਰੀ ਹਨ। ਜਿੰਨੀ ਦੇਰ ਉਸ ਦਾ ਨਾਂ ਨਹੀਂ ਕੱਟਿਆ ਜਾਂਦਾ, ਉਸ ਨੂੰ ਫੀਸਾਂ ਦੇਣੀਆਂ ਪੈਣਗੀਆਂ। ਕਾਲਜ ਛੱਡਣ ਦਾ ਸਰਟੀਫਿਕੇਟ No dues/clearance ਉਪਰੰਤ ਹੀ ਮਿਲੇਗਾ।

## FINANCIAL ASSISTANCE TO THE NEEDY AND DESERVING:

1. ਹੇਠਲੀ ਪ੍ਰੀਖਿਆ ਵਿਚੋਂ 90% ਜਾਂ ਇਸ ਤੋਂ ਵੱਧ ਅੰਕ ਪ੍ਰਾਪਤ ਕਰਨ ਵਾਲੀਆਂ ਵਿਦਿਆਰਥਣਾਂ ਨੂੰ ਫੀਸ ਵਿਚ ਰਿਆਇਤ ਦਿੱਤੀ ਜਾਵੇਗੀ।
2. ਪੱਛਤੀ ਸ਼੍ਰੇਣੀ ਅਤੇ ਅਨੁਸੂਚਿਤ ਜਾਤੀਆਂ ਦੀਆਂ ਵਿਦਿਆਰਥਣਾਂ ਨੂੰ ਸਰਕਾਰ scholarship ਦਿੱਤੀ ਹੈ।

## REFUND OF SECURITY:

ਹੋਸਟਲ ਅਤੇ ਲਾਇਬ੍ਰੇਰੀ ਦੀ ਸਕਿਊਰਟੀ ਕਾਲਜ ਛੱਡਣ ਤੋਂ ਛੇ ਮਹੀਨੇ ਵਿੱਚ ਲਈ ਜਾਵੇ ਉਸਤੋਂ ਬਾਅਦ ਸਕਿਊਰਟੀ ਨਹੀਂ ਮਿਲੇਗੀ।

## SCHOLARSHIP/STIPENDS/FINANCIAL ASSISTANCE TO STUDENTS:

ਵੱਖ-ਵੱਖ ਅਤੇ ਹੋਰ ਆਰਥਿਕ ਸਹਾਇਤਾ ਹੁਸ਼ਿਆਰ ਵਿਦਿਆਰਥਣਾਂ ਨੂੰ ਉਨ੍ਹਾਂ ਦੇ ਖਰਚ ਪੂਰਾ ਕਰਨ ਲਈ ਦਿੱਤੇ ਜਾਂਦੇ ਹਨ। ਇਸ ਸਬੰਧੀ ਕਾਲਜ ਦੇ ਫੋਪੋ ਫਾਰਮ ਤੇ ਦਾਖਲੇ ਦਾ ਮਿਤੀ ਤੋਂ 15 ਦਿਨਾਂ ਦੇ ਅੰਦਰ ਬਿਨੇ-ਪੱਤਰ ਦੇਣੇ ਜ਼ਰੂਰੀ ਹਨ। ਹੇਠ ਲਿਖੇ ਵੱਖ-ਵੱਖ ਅਤੇ ਆਰਥਿਕ ਸਹਾਇਤਾ ਦਿੱਤੇ ਜਾਂਦੇ ਹਨ।

1. University Scholarships: These are presented on the basis of merit.
2. Scholarships by the Punjab Education Board: These are presented by the Punjab Govt. on the basis of merit.
3. National Scholarships: These are presented by the Central Govt. on the basis of merit.
4. Scholarships for Scheduled Castes/ Tribes and Backward Classes: These are presented by the Indian Government.
5. **Post-Matric scholarships for Scheduled castes** : Student must belong to Scheduled caste and family income from all sources must not exceed Rs. 2,50,000/-.
6. **Post-Matric scholarships for Minorities** : Student must belong to minority group and income from all sources must not exceed Rs. 2,00,000.
7. **Merit Scholarship** is offered to students, based on the 10+2 marks. 90% & above marks -25%. 80% - 89% marks -10%.
8. **Sibling concession** is provided in case siblings [two sisters] are enrolled in our institution. A fee concession is offered to the second sibling until the first sibling studies in our institution.
9. The institution helps such students who face **financial hardships** and applications for the same need to be forwarded to the Principal for availing benefit.
10. **Single girl child scholarship** is offered by Panjab University Chandigarh.
11. **Sikh Human Development Foundation [SHDF] Scholarship** is offered by Nishkam Sikh Welfare Council to students who are pursuing professional courses like BCA, BA/BED and BSC/BED. Student must possess at least 60% marks in the last two exams and family income must not exceed 1,50,000-1,80,000.
12. PM Young Achievers Scholarship Award Scheme for Vibrant India for OBC's and others (PM-Yasavi) - It is a centrally sponsored scheme of Post-Matric Scholarship for OBC, EBC & DNT students for studying in India.
13. Book grant for the children of political sufferers: incentives and schemes for students belonging to Scheduled castes, backward castes, Vimukt castes and low-income groups for their education.
14. Post Matric Scholarship Scheme: Under this scheme of the Indian Govt. permanent residents of Punjab belonging to Scheduled Castes are permitted scholarships in any part of India for purposes of Post Matric/secondary education. Their family income from all sources must not exceed Rs. 2,50,000/- (further information concerning this scheme can be obtained from the scholarship branch of the college).
15. Milki Ram Sharma Memorial Scholarship 250/- PM will be given to a student of M.A./M.Sc. class who is a resident of District "UNA" in Himachal Pradesh.
16. "The list of scholarships which are being awarded to the students of affiliated college by office of Dean College Development Council in the following categories is available on the website of Dean, College Development Council Panjab University i.e. <http://dcdc.puchd.ac.in/>.

1. Means Cum merit

2. Sports

Prospectus 2023-24

3. Single Girl Child
4. Physically Disabled
5. AIDS/Cancer patient
6. Youth Welfare
7. Transgender

17. ਵਿਦਿਆਰਥੀ ਸਹਾਇਤਾ ਫੰਡ: ਵਿਦਿਆਰਥੀ ਸਹਾਇਤਾ ਫੰਡ ਵਿੱਚੋਂ ਗਰੀਬ ਵਿਦਿਆਰਥਣਾਂ ਨੂੰ ਫ਼ੀਸ ਅਤੇ ਕਿਤਾਬਾਂ ਖਰੀਦਣ ਲਈ ਸਹਾਇਤਾ ਮਿਲਦੀ ਹੈ।
18. ਸ੍ਰੀ ਗੁਰੂ ਹਰਿਗੋਬਿੰਦ ਉਜਾਗਰ ਹਰੀ ਟਰੱਸਟ ਵੱਲੋਂ ਸੰਸਥਾਵਾਂ ਦੇ ਬਾਨੀਆਂ ਦੀ ਯਾਦ ਵਿੱਚ ਅਕਾਦਮਿਕ ਖੇਤਰ, ਖੇਡਾਂ ਅਤੇ ਧਾਰਮਿਕ ਖੇਤਰ ਵਿੱਚ ਸ਼ਾਨਦਾਰ ਪ੍ਰਾਪਤੀਆਂ ਕਰਨ ਵਾਲੀਆਂ ਵਿਦਿਆਰਥਣਾਂ ਨੂੰ 1 ਲੱਖ ਰੁਪਏ ਤੋਂ ਵੱਧ ਦੇ ਵਜ਼ੀਫ਼ੇ ਦਿੱਤੇ ਜਾਂਦੇ ਹਨ।
19. ਕਾਲਜ ਦੇ ਕੁੱਝ ਅਧਿਆਪਕ ਸਹਿਬਾਨ ਲੋੜਵੰਦ ਵਿਦਿਆਰਥਣਾਂ ਨੂੰ ਗੁਪਤ ਦਾਨ ਵਜੋਂ ਫ਼ੀਸ ਰਿਆਇਤ ਦਿੰਦੇ ਹਨ।

In addition to above information other scholarships available to the students of Panjab university are also available on Panjab University website: <http://puuchd.ac.in/>

19

**KHALSA COLLEGE FOR WOMEN, SIDHWAN KHURD**  
**LIST OF STUDENTS GETTING CONCESSION**  
**IN THE COLLEGE FEE**  
**FOR THE SESSION 2023-24**

TYPE OF COCESSION	NO. OF STUDENTS	AMOUNT
10%	68	245033
20%	13	90865
25%	24	218206
SIBLING CONCESSION	6	9630
SPORTS CONCESSION	1	20891
<b>TOTAL</b>	<b>112</b>	<b>584625</b>

FEE CONCESSION COMMITTEE

MRS. HARDEEP KAUR



MRS. HARWINDER KAUR

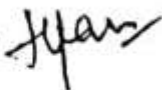

PRINCIPAL  
Khalisa College for Women  
Sidhwan Khurd (Ludhiana)



Principal



21.10.23.24



# Dr. Ambedkar

## Scholarship Portal

### Punjab Government

Government of Punjab Social Justice & Empowerment Department Sanction Order

Date : 11-Mar-2024

Scholarship Scheme : Post Matric Scholarship Scheme for SC	Sanction Authority : Tehsil Welfare officer Jagraon	59215
Category :	Sanction Number : R/8385/1/1/59215	
Institute Name : K C W sichwankhurd	Sanction Date : 23/02/2024	59215
Academic Year : 2023-24	Application Type : Renewal	

Sl. No.	Roll No.	Name	Gender	Course	Level	Grade	Monthly Allowance	Disbursement	Balance	Remarks		
1	650075	INDERPREET KAUR S/O/D LAKHWIR SINGH	Female	B. Sc./B. Sc. B.Ed. / 3Yr	Renewal	12	3000	3000	15249	0	15249	18249
2	641944	MANDEEP KAUR S/O/D KULDEEP SINGH	Female	B. Com./Bachelor in Commerce / 3Yr	Renewal	12	3000	3000	9598	0	9598	12598
3	622933	SIMRANPREET KAUR S/O/D CHAMKAUR SINGH	Female	B. Com./Bachelor in Commerce / 3Yr	Renewal	12	3000	3000	9598	0	9598	12598
4	506187	RAMANJOT KAUR S/O/D ACHHRU SINGH	Female	B. Com./Bachelor in Commerce / 2Yr	Renewal	12	3000	3000	9598	0	9598	12598
5	468958	SUKHPREET KAUR S/O/D JINDER SINGH	Female	B. Com./Bachelor in Commerce / 2Yr	Renewal	12	3000	3000	9598	0	9598	12598
6	824879	PRABHJOT KAUR S/O/D BUTA SINGH	Female	B. Com./Bachelor in Commerce / 2Yr	Renewal	12	3000	3000	9598	0	9598	12598
7	447744	KOMALPREET KAUR S/O/D JAGSHIR SINGH	Female	B. Com./Bachelor in Commerce / 2Yr	Renewal	12	3000	3000	9598	0	9598	12598
8	657068	MANDEEP KAUR S/O/D PALA SINGH	Female	B. A/B A / 3Yr	Renewal	12	3000	3000	18281	0	18281	21281
9	845643	SUKHDEEP KAUR S/O/D JAGTAR SINGH	Female	B. A/B A / 2Yr	Renewal	12	3000	3000	17396	0	17396	20396
10	673701	HARMANPREET KAUR S/O/D SUKHMINDER SINGH	Female	B. A/B A / 2Yr	Renewal	12	3000	3000	17396	0	17396	20396
11	587931	NAVJOT KAUR S/O/D JASVIR SINGH	Female	B. A/B A / 3Yr	Renewal	12	3000	3000	18281	0	18281	21281
12	837238	SUKHDEEP KAUR S/O/D RANJOOH SINGH	Female	B. A/B A / 2Yr	Renewal	12	3000	3000	17396	0	17396	20396
13	366078	MANVEER KAUR S/O/D KULDEEP SINGH	Female	B. A/B A / 3Yr	Renewal	12	3000	3000	18281	0	18281	21281
14	388621	SHIVANI S/O/D RAJ KUMAR	Female	B. A/B A / 3Yr	Renewal	12	3000	3000	18281	0	18281	21281
15	388606	NISHA S/O/D RAJ KUMAR	Female	B. A/B A / 3Yr	Renewal	12	3000	3000	18281	0	18281	21281





**Dr. Ambedkar**  
Scholarship Portal  
Punjab Government

Government of Punjab Social Justice & Empowerment Department Sanction Order										Date : 11-Mar-2024		
16	569308	KOMALPREET KAUR S/D/O -RESHAM SINGH	Female	B. A./B.A / 2Yr	Renewal	12	3000	3000	17396	0	17396	20396
17	679678	GURPREET KAUR S/D/O -KARAMPAL SINGH	Female	B. A./B.A / 3Yr	Renewal	12	3000	3000	18281	0	18281	21281
18	748416	SIMRANDEEP KAUR S/D/O -CHAMKAUR SINGH	Female	B. A./B.A / 2Yr	Renewal	12	3000	3000	17396	0	17396	20396
19	830373	RAJDEEP KAUR S/D/O -NAKAM SINGH	Female	B. A./B.A / 2Yr	Renewal	12	3000	3000	17396	0	17396	20396
20	805270	HARPREET KAUR S/D/O -JAGSIR SINGH	Female	B. A./B.A / 2Yr	Renewal	12	3000	3000	17396	0	17396	20396
21	582036	JASPHINDER KAUR S/D/O -GURVINDER SINGH	Female	B. A./B.A / 3Yr	Renewal	12	3000	3000	18281	0	18281	21281
22	614599	ARSHDEEP KAUR S/D/O -AJITAR SINGH	Female	B. A./B.A / 2Yr	Renewal	12	3000	3000	17396	0	17396	20396
23	663412	MANPREET KAUR S/D/O -RAJA SINGH	Female	B. A./B.A / 3Yr	Renewal	12	3000	3000	18281	0	18281	21281
24	781605	SANDEEP KAUR S/D/O -KULDEEP SINGH	Female	B. A./B.A / 2Yr	Renewal	12	3000	3000	17396	0	17396	20396
25	588757	GURBINDER KAUR S/D/O -NIRMAL SINGH	Female	B. Sc./B.Sc Non-Medical / 3Yr	Renewal	12	3000	3000	9778	0	9778	12778
26	647523	SURHEET KAUR S/D/O -GURNAM SINGH	Female	B. Sc./B.Sc Non-Medical / 3Yr	Renewal	12	3000	3000	9778	0	9778	12778
27	561588	RAVINDER KAUR S/D/O -MAJOR SINGH	Female	B. Sc./B.Sc Non-Medical / 3Yr	Renewal	12	3000	3000	9778	0	9778	12778
28	695805	MUSKANPREET KAUR S/D/O -BALVIR SINGH	Female	B. Sc./B.Sc Non-Medical / 2Yr	Renewal	12	3000	3000	9778	0	9778	12778
29	871410	SANDEEP KAUR S/D/O -JAGDEV SINGH	Female	B. Sc./B.Sc Non-Medical / 2Yr	Renewal	12	3000	3000	9778	0	9778	12778
30	918297	KIRANJIT KAUR S/D/O -SUKNWINDER SINGH	Female	Bachelor of Education/B.A. * BED / 2Yr	Renewal	12	3000	3000	15249	0	15249	18249
31	618386	EKANPREET KAUR S/D/O -JASVIR SINGH	Female	Bachelor of Computer Application/BCA / 3Yr	Renewal	12	7000	7000	33278	0	33278	40278
32	542893	MANVEER KAUR S/D/O -KULDEEP SINGH	Female	Bachelor of Computer Application/BCA / 2Yr	Renewal	12	7000	7000	32450	0	32450	39450

NIC

Government of Punjab Social Justice & Empowerment Department Sanction Order										Date : 11-Mar-2024		
33	836418	RAMANDEEP KAUR S/D/O -KULWANT SINGH	Female	B. A./B.A / 2Yr	Renewal	12	3000	3000	17396	0	17396	20396
34	845944	MANTEJ KAUR S/D/O -TIRATH SINGH	Female	B. A./B.A / 2Yr	Renewal	12	3000	3000	17396	0	17396	20396
35	650086	GAGANDEEP KAUR S/D/O -JAGMAIL SINGH	Female	B. A./B.A / 3Yr	Renewal	12	3000	3000	18281	0	18281	21281
36	584919	GAGANDEEP KAUR S/D/O -SUKNWINDER SINGH	Female	B. A./B.A / 2Yr	Renewal	12	3000	3000	17396	0	17396	20396
37	853632	GAGANDEEP KAUR S/D/O -AJIT SINGH	Female	B. A./B.A / 2Yr	Renewal	12	3000	3000	17396	0	17396	20396
38	866108	KIRAN KAUR S/D/O -BHAJAN SINGH	Female	B. A./B.A / 2Yr	Renewal	12	3000	3000	17396	0	17396	20396
39	849283	RAJWANT KAUR S/D/O -JASVIR SINGH	Female	B. A./B.A / 2Yr	Renewal	12	3000	3000	17396	0	17396	20396
40	875268	JASPREET KAUR S/D/O -JASWANT SINGH	Female	B. A./B.A / 2Yr	Renewal	12	3000	3000	17396	0	17396	20396
41	413817	POOJA S/D/O -RAM SAVANRE	Female	B. A./B.A / 3Yr	Renewal	12	3000	3000	18281	0	18281	21281
42	870697	SURHANDEEP KAUR S/D/O -JAGTAR SINGH	Female	B. A./B.A / 2Yr	Renewal	12	3000	3000	17396	0	17396	20396
43	891903	RAJANPREET KAUR S/D/O -GURCHARAN SINGH	Female	B. A./B.A / 2Yr	Renewal	12	3000	3000	17396	0	17396	20396
44	660789	MANROOP KAUR S/D/O -AVTAR SINGH	Female	B. A./B.A / 3Yr	Renewal	12	3000	3000	18281	0	18281	21281
45	874629	KAMALPREET KAUR S/D/O -DAVINDER SINGH	Female	B. A./B.A / 2Yr	Renewal	12	3000	3000	17396	0	17396	20396
46	552199	KIRANDEEP KAUR S/D/O -DALIT SINGH	Female	B. Com./B.Com / 2Yr	Renewal	12	3000	3000	9558	0	9558	12558
47	507580	RAMANPREET KAUR S/D/O -DALIT SINGH	Female	B. Com./B.Com / 2Yr	Renewal	12	3000	3000	9558	0	9558	12558
48	548285	ASHWINDER KAUR S/D/O -PARMINDER SINGH	Female	M.A./M.A English / 2Yr	Renewal	12	3000	3000	10898	0	10898	21898
49	456258	RAJINDER KAUR S/D/O -HARBANS SINGH	Female	M.Com/M.com / 2Yr	Renewal	12	3000	3000	15673	0	15673	18673
50	447106	MANDEEP KAUR S/D/O -NIRMAL SINGH	Female	B. A./B.A. B.Ed. / 4Yr	Renewal	12	3000	3000	15249	0	15249	18249
51	477179	GURPREET KAUR S/D/O -GURMUKH SINGH	Female	B. A./B.A. B.Ed. / 4Yr	Renewal	12	3000	3000	15249	0	15249	18249

NIC

# Dr. Ambedkar

## Scholarship Portal

### Punjab Government

Government of Punjab Social Justice & Empowerment Department Sanction Order

Date : 11-Mar-2024

Scholarship Scheme : Post Matric Scholarship Scheme for SC	Sanction Authority : Tehsil Welfare officer Jagraon	59215
Category :	Sanction Number : RB/8385/1/1/59215	
Institute Name : K C W sichwankhurd	Sanction Date : 23/02/2024	59215
Academic Year : 2023-24	Application Type : Renewal	

Sl. No.	Roll No.	Name	Gender	Course	Level	Grade	Monthly Allowance	Family Income	Other Income	Net Income	Sanctioned Amount	Remarks
1	650075	INDERPREET KAUR S/O/D LAKHWIR SINGH	Female	B. Sc./B. Sc. B.Ed. / 3Yr	Renewal	12	3000	3000	15249	0	15249	18249
2	641944	MANDEEP KAUR S/O/D KULDEEP SINGH	Female	B. Com./Bachelor in Commerce / 3Yr	Renewal	12	3000	3000	9598	0	9598	12598
3	622933	SIMRANPREET KAUR S/O/D CHAMKAUR SINGH	Female	B. Com./Bachelor in Commerce / 3Yr	Renewal	12	3000	3000	9598	0	9598	12598
4	506187	RAMANJOT KAUR S/O/D ACHHRU SINGH	Female	B. Com./Bachelor in Commerce / 2Yr	Renewal	12	3000	3000	9598	0	9598	12598
5	468958	SUKHPREET KAUR S/O/D JINDER SINGH	Female	B. Com./Bachelor in Commerce / 2Yr	Renewal	12	3000	3000	9598	0	9598	12598
6	824879	PRABHJOT KAUR S/O/D BUTA SINGH	Female	B. Com./Bachelor in Commerce / 2Yr	Renewal	12	3000	3000	9598	0	9598	12598
7	447744	KOMALPREET KAUR S/O/D JAGSHIR SINGH	Female	B. Com./Bachelor in Commerce / 2Yr	Renewal	12	3000	3000	9598	0	9598	12598
8	657068	MANDEEP KAUR S/O/D PALA SINGH	Female	B. A/B A / 3Yr	Renewal	12	3000	3000	18281	0	18281	21281
9	845643	SUKHDEEP KAUR S/O/D JAGTAR SINGH	Female	B. A/B A / 2Yr	Renewal	12	3000	3000	17396	0	17396	20396
10	673701	HARMANPREET KAUR S/O/D SUKHMINDER SINGH	Female	B. A/B A / 2Yr	Renewal	12	3000	3000	17396	0	17396	20396
11	587931	NAVJOT KAUR S/O/D JASVIR SINGH	Female	B. A/B A / 3Yr	Renewal	12	3000	3000	18281	0	18281	21281
12	837238	SUKHDEEP KAUR S/O/D RANJOOH SINGH	Female	B. A/B A / 2Yr	Renewal	12	3000	3000	17396	0	17396	20396
13	366078	MANVEER KAUR S/O/D KULDEEP SINGH	Female	B. A/B A / 3Yr	Renewal	12	3000	3000	18281	0	18281	21281
14	388621	SHIVANI S/O/D RAJ KUMAR	Female	B. A/B A / 3Yr	Renewal	12	3000	3000	18281	0	18281	21281
15	388606	NISHA S/O/D RAJ KUMAR	Female	B. A/B A / 3Yr	Renewal	12	3000	3000	18281	0	18281	21281





**Dr. Ambedkar**  
Scholarship Portal  
Punjab Government

Government of Punjab Social Justice & Empowerment Department Sanction Order Date : 11-Mar-2024

16	569308	KOMALPREET KAUR S/O-D RISHAM SINGH	Female	B. A./B.A / 2Yr	Renewal	12	3000	3000	17396	0	17396	20396
17	679678	GURPREET KAUR S/O-KARAMPAL SINGH	Female	B. A./B.A / 3Yr	Renewal	12	3000	3000	18281	0	18281	21281
18	748416	SIMRANDEEP KAUR S/O-CHAMKAUR SINGH	Female	B. A./B.A / 2Yr	Renewal	12	3000	3000	17396	0	17396	20396
19	830373	RAJDEEP KAUR S/O-NAKAM SINGH	Female	B. A./B.A / 2Yr	Renewal	12	3000	3000	17396	0	17396	20396
20	805270	HARPREET KAUR S/O-JAGSIR SINGH	Female	B. A./B.A / 2Yr	Renewal	12	3000	3000	17396	0	17396	20396
21	582036	JASPHINDER KAUR S/O-GURVINDER SINGH	Female	B. A./B.A / 3Yr	Renewal	12	3000	3000	18281	0	18281	21281
22	614599	ARSHODEEP KAUR S/O-AJATAR SINGH	Female	B. A./B.A / 2Yr	Renewal	12	3000	3000	17396	0	17396	20396
23	663412	MANPREET KAUR S/O-RAJA SINGH	Female	B. A./B.A / 3Yr	Renewal	12	3000	3000	18281	0	18281	21281
24	781605	SANDEEP KAUR S/O-KULDEEP SINGH	Female	B. A./B.A / 2Yr	Renewal	12	3000	3000	17396	0	17396	20396
25	588757	GURBINDER KAUR S/O-NIRMAL SINGH	Female	B. Sc./B.Sc Non-Medical / 3Yr	Renewal	12	3000	3000	9778	0	9778	12778
26	647523	SURHEET KAUR S/O-GURNAM SINGH	Female	B. Sc./B.Sc Non-Medical / 3Yr	Renewal	12	3000	3000	9778	0	9778	12778
27	561588	RAVINDER KAUR S/O-MAJOR SINGH	Female	B. Sc./B.Sc Non-Medical / 3Yr	Renewal	12	3000	3000	9778	0	9778	12778
28	695805	MUSKANPREET KAUR S/O-BALVIR SINGH	Female	B. Sc./B.Sc Non-Medical / 2Yr	Renewal	12	3000	3000	9778	0	9778	12778
29	871410	SANDEEP KAUR S/O-JAGDEV SINGH	Female	B. Sc./B.Sc Non-Medical / 2Yr	Renewal	12	3000	3000	9778	0	9778	12778
30	918297	KIRANJIT KAUR S/O-SUKHWINDER SINGH	Female	Bachelor of Education/B.A. * BED / 2Yr	Renewal	12	3000	3000	15249	0	15249	18249
31	618386	EKANPREET KAUR S/O-JASVIR SINGH	Female	Bachelor of Computer Application/BCA / 3Yr	Renewal	12	7000	7000	33278	0	33278	40278
32	542893	MANVEER KAUR S/O-KULDEEP SINGH	Female	Bachelor of Computer Application/BCA / 2Yr	Renewal	12	7000	7000	32450	0	32450	39450

NIC

**Dr. Ambedkar**  
Scholarship Portal  
Punjab Government

Government of Punjab Social Justice & Empowerment Department Sanction Order Date : 11-Mar-2024

33	836418	RAMANDEEP KAUR S/O-KULWANT SINGH	Female	B. A./B.A / 2Yr	Renewal	12	3000	3000	17396	0	17396	20396
34	845944	MANTEJ KAUR S/O-TIRATH SINGH	Female	B. A./B.A / 2Yr	Renewal	12	3000	3000	17396	0	17396	20396
35	650086	GAGANDEEP KAUR S/O-JAGMAIL SINGH	Female	B. A./B.A / 3Yr	Renewal	12	3000	3000	18281	0	18281	21281
36	584919	GAGANDEEP KAUR S/O-SUKHWINDER SINGH	Female	B. A./B.A / 2Yr	Renewal	12	3000	3000	17396	0	17396	20396
37	853652	GAGANDEEP KAUR S/O-AJIT SINGH	Female	B. A./B.A / 2Yr	Renewal	12	3000	3000	17396	0	17396	20396
38	866108	KIRAN KAUR S/O-SHALAN SINGH	Female	B. A./B.A / 2Yr	Renewal	12	3000	3000	17396	0	17396	20396
39	849283	RAJWANT KAUR S/O-JASVIR SINGH	Female	B. A./B.A / 2Yr	Renewal	12	3000	3000	17396	0	17396	20396
40	875268	JASPREET KAUR S/O-JASWANT SINGH	Female	B. A./B.A / 2Yr	Renewal	12	3000	3000	17396	0	17396	20396
41	413817	POOJA S/O-RAM SAVANRE	Female	B. A./B.A / 3Yr	Renewal	12	3000	3000	18281	0	18281	21281
42	870697	SURHANDEEP KAUR S/O-AJATAR SINGH	Female	B. A./B.A / 2Yr	Renewal	12	3000	3000	17396	0	17396	20396
43	891903	RAJANPREET KAUR S/O-GURCHARAN SINGH	Female	B. A./B.A / 2Yr	Renewal	12	3000	3000	17396	0	17396	20396
44	660789	MANROOP KAUR S/O-AVTAR SINGH	Female	B. A./B.A / 3Yr	Renewal	12	3000	3000	18281	0	18281	21281
45	874629	KAMALPREET KAUR S/O-DAVINDER SINGH	Female	B. A./B.A / 2Yr	Renewal	12	3000	3000	17396	0	17396	20396
46	552199	KIRANDEEP KAUR S/O-DALIT SINGH	Female	B. Com./B.Com / 2Yr	Renewal	12	3000	3000	9558	0	9558	12558
47	507580	RAMANPREET KAUR S/O-DALIT SINGH	Female	B. Com./B.Com / 2Yr	Renewal	12	3000	3000	9558	0	9558	12558
48	548285	ASHWINDER KAUR S/O-PARMINDER SINGH	Female	M.A./MA English / 2Yr	Renewal	12	3000	3000	10898	0	10898	21898
49	496258	RAJINDER KAUR S/O-HARBANS SINGH	Female	M.Com/M.com / 2Yr	Renewal	12	3000	3000	15673	0	15673	18673
50	447106	MANDEEP KAUR S/O-HARMAL SINGH	Female	B. A./B.A. B.Ed. / 4Yr	Renewal	12	3000	3000	15249	0	15249	18249
51	477179	GURPREET KAUR S/O-GURMUKH SINGH	Female	B. A./B.A. B.Ed. / 4Yr	Renewal	12	3000	3000	15249	0	15249	18249

NIC



# Dr. Ambedkar

Scholarship Portal

by Punjab Government

Government of Punjab Social Justice & Empowerment Department Sanction Order

Date : 11-Mar-2024

Sl. No.	Applicant ID	Applicant Name	Gender	Course	Application Type	Months	Stipend	Allowance	Other Fee	Total	Net Amount	
52	700425	JASPREET KAUR S/D/O -JASPAL SINGH	Female	B. A./B.A. B.Ed. / 3Yr	Renewal	12	3000	3000	15249	0	15249	18249
53	706199	SAROJDEEP KAUR S/D/O -HARPAL SINGH	Female	B. A./B.A. B.Ed. / 3Yr	Renewal	12	3000	3000	15249	0	15249	18249
54	867062	AMARPREET KAUR S/D/O -RAJINDER SINGH	Female	B. A./B.A. B.Ed. / 2Yr	Renewal	12	3000	3000	15249	0	15249	18249
55	646517	LOVEJOT KAUR S/D/O -LAKHVIR SINGH	Female	B. A./B.A. B.Ed. / 3Yr	Renewal	12	3000	3000	15249	0	15249	18249
56	686166	NAVDEEP KAUR S/D/O -SUHKMINDER SINGH	Female	B. A./B.A. B.Ed. / 3Yr	Renewal	12	3000	3000	15249	0	15249	18249
57	506137	GAGANDEEP KAUR S/D/O -GURPREET SINGH	Female	B. A./B.A. B.Ed. / 2Yr	Renewal	12	3000	3000	15249	0	15249	18249
58	706265	AKASHDEEP KAUR S/D/O -HARPAL SINGH	Female	B. A./B.A. B.Ed. / 3Yr	Renewal	12	3000	3000	15249	0	15249	18249

# Dr. Ambedkar

Scholarship Portal

by Punjab Government

Government of Punjab Social Justice & Empowerment Department Sanction Order

Date : 11-Mar-2024

Scholarship Scheme : Post Matric Scholarship Scheme for SC  
 Category : \_\_\_\_\_  
 Institute Name : K C W sidhwankhurd  
 Academic Year : 2023-24  
 Sanction Authority : Tehsil Welfare officer Jagraon  
 Sanction Number : N/B/8385/1/1/59212  
 Sanction Date : 23/02/2024  
 Application Type : Fresh

Sl. No.	Applicant ID	Applicant Name	Gender	Course	Application Type	Months	Stipend	Allowance	Other Fee	Total	Net Amount	
1	661354	KAMALPREET KAUR S/D/O -NAZAR SINGH	Female	B. Sc./B.Sc Medical / 1Yr	Fresh	10	3000	3000	11258	0	11258	14258
2	921788	KAMALVEER KAUR S/D/O -BHUPINDER SINGH	Female	M.A./M.A History / 1Yr	Fresh	10	3000	3000	18998	0	18998	21998
3	917150	VARINDERJIT KAUR S/D/O -NINDER SINGH	Female	B. Com /Bachelor in Commerce / 1Yr	Fresh	10	3000	3000	10898	0	10898	13898
4	686121	AMANPREET KAUR S/D/O -BHAGWAN DASS	Female	B. Com /Bachelor in Commerce / 1Yr	Fresh	10	3000	3000	10898	0	10898	13898
5	534873	GURWINDER KAUR S/D/O -GURMEL SINGH	Female	B. A./B.A / 1Yr	Fresh	10	3000	3000	18496	0	18496	21496
6	929220	RAJWINDER KAUR S/D/O -SATPAL SINGH	Female	B. A./B.A / 1Yr	Fresh	10	3000	3000	18496	0	18496	21496
7	731302	PARDEEP KAUR S/D/O -BALDEV SINGH	Female	B. A./B.A / 1Yr	Fresh	10	3000	3000	18496	0	18496	21496
8	930838	MANPREET KAUR S/D/O -BALVIR SINGH	Female	B. A./B.A / 1Yr	Fresh	10	3000	3000	18496	0	18496	21496
9	850003	POOJA RANI S/D/O -BALWINDER SINGH	Female	B. A./B.A / 1Yr	Fresh	10	3000	3000	18496	0	18496	21496
10	654411	NANKI S/D/O -AJIT SINGH	Female	B. A./B.A / 1Yr	Fresh	10	3000	3000	18496	0	18496	21496
11	957954	KOMALPREET KAUR S/D/O -KULWINDER SINGH	Female	B. A./B.A / 1Yr	Fresh	10	3000	3000	18496	0	18496	21496
12	917970	RAMANDEEP KAUR S/D/O -SURJIT SINGH	Female	B. A./B.A / 1Yr	Fresh	10	3000	3000	18496	0	18496	21496
13	921941	ISTAR KAUR S/D/O -BALJINDER SINGH	Female	B. A./B.A / 1Yr	Fresh	10	3000	3000	18496	0	18496	21496
14	791722	AMANDEEP KAUR S/D/O -SUHKMINDER SINGH	Female	B. A./B.A / 1Yr	Fresh	10	3000	3000	18496	0	18496	21496

**Dr. Ambedkar**  
 Scholarship Portal  
 by  
**Punjab Government**  
 Government of Punjab Social Justice & Empowerment Department Sanction Order

Date : 11-Mar-2024

15	683024	PALWINDER KAUR S/O - KULDEEP SINGH	Female	B. A/B.A / 1Yr	Fresh	10	3000	3000	18496	0	18496	21496
16	671679	MANPREET KAUR S/O - HARPREET SINGH	Female	B. A/B.A / 1Yr	Fresh	10	3000	3000	18496	0	18496	21496
17	688859	ARSHPREET KAUR S/O - JASVIR SINGH	Female	B. A/B.A / 1Yr	Fresh	10	3000	3000	18496	0	18496	21496
18	776052	PARWINDER KAUR S/O - JASWANT SINGH	Female	B. A/B.A / 1Yr	Fresh	10	3000	3000	18496	0	18496	21496
19	705462	PAJAL KAUR S/O - HARNAM SINGH	Female	B. A/B.A / 1Yr	Fresh	10	3000	3000	18496	0	18496	21496
20	923474	AMANPREET KAUR S/O - BHUPINDER SINGH	Female	B. A/B.A / 1Yr	Fresh	10	3000	3000	18496	0	18496	21496
21	855244	SUMANDEEP KAUR S/O - TARSEM SINGH	Female	B. A/B.A / 1Yr	Fresh	10	3000	3000	18496	0	18496	21496
22	652490	HARMANDEEP KAUR S/O - MAGHAR SINGH	Female	B. A/B.A / 1Yr	Fresh	10	3000	3000	18496	0	18496	21496
23	664670	VEERPAL KAUR S/O - CHARAN SINGH	Female	B. A/B.A / 1Yr	Fresh	10	3000	3000	18496	0	18496	21496
24	729443	HARPREET KAUR S/O - RAM SAROOP	Female	B. A/B.A / 1Yr	Fresh	10	3000	3000	18496	0	18496	21496
25	724175	SUMANPREET KAUR S/O - CHARAN SINGH	Female	M.A/MA Punjabi / 1Yr	Fresh	10	3000	3000	18896	0	18896	21896
26	749734	SUMANDEEP KAUR S/O - SATNAM SINGH	Female	M.A/MA Punjabi / 1Yr	Fresh	10	3000	3000	18896	0	18896	21896
27	467009	JEEWANJOT KAUR S/O - HARI SINGH	Female	M.Com/M.com / 1Yr	Fresh	10	3000	3000	14223	0	14223	17223
28	449500	AMANDEEP KAUR S/O - JASWINDER SINGH	Female	M.Com/M.com / 1Yr	Fresh	10	3000	3000	14223	0	14223	17223
29	475773	KIRANDEEP KAUR S/O - MAUKIT SINGH	Female	M.Com/M.com / 1Yr	Fresh	10	3000	3000	14223	0	14223	17223
30	919471	AMRITA DEVI S/O - KAMAL KUMAR	Female	B. A/B.A. B.Ed / 1Yr	Fresh	10	3000	3000	15249	0	15249	18249
31	922545	HARJOT KAUR S/O - NEK SINGH	Female	B. Sc./B.Sc Non-Medical / 1Yr	Fresh	10	3000	3000	11078	0	11078	14078
32	918516	PARAJIT KAUR S/O - RAJ SINGH	Female	B. Sc./B.Sc Non-Medical / 1Yr	Fresh	10	3000	3000	11078	0	11078	14078
33	931617	SIMRANDEEP KAUR S/O - JASVIR SINGH	Female	B. Sc./B.Sc Non-Medical / 1Yr	Fresh	10	3000	3000	11078	0	11078	14078



# Dr. Ambedkar

Scholarship Portal  
by  
Punjab Government

Government of Punjab Social Justice & Empowerment Department Sanction Order

Date : 11-Mar-2024

34	737526	SHAHNAJ RANI S/D/O-BINDER SINGH	Female	Bachelor of Education/B.A.+ BED / 1Yr	Fresh	10	6000	6000	15249	0	15249	21249
35	654425	AMANDEEP KAUR S/D/O -RASHPAL SINGH	Female	Bachelor of Education/B.A.+ BED / 1Yr	Fresh	10	3000	3000	15249	0	15249	18249
36	936095	RAJANDEEP KAUR S/D/O -JAGDEV SINGH	Female	Bachelor of Education/B.A.+ BED / 1Yr	Fresh	10	3000	3000	15249	0	15249	18249
37	699575	HARDEEP KAUR S/D/O -SHINDER SINGH	Female	Bachelor of Education/B.A.+ BED / 1Yr	Fresh	10	6000	6000	15249	0	15249	21249
38	919275	HARMANPREET KAUR S/D/O -KARAMJIT SINGH	Female	Bachelor of Education/B.A.+ BED / 1Yr	Fresh	10	3000	3000	15249	0	15249	18249
39	998443	SUKHPREET KAUR S/D/O -GURDEEP SINGH	Female	Bachelor of Education/B.A.+ BED / 1Yr	Fresh	10	3000	3000	15249	0	15249	18249
40	799788	MANISHA RANI S/D/O -SANDHEEP SINGH	Female	Bachelor of Education/B.Sc.+ BED / 1Yr	Fresh	10	6000	6000	15249	0	15249	21249
11	943600	SONIKA RANI S/D/O -BALWINDER SINGH	Female	Bachelor of Education/B.Sc.+ BED / 1Yr	Fresh	10	6000	6000	15249	0	15249	21249
12	889040	KOMAL RANI S/D/O -HARBANS SINGH	Female	Bachelor of Education/B.Sc.+ BED / 1Yr	Fresh	10	6000	6000	15249	0	15249	21249
13	922278	RAJANPREET KAUR S/D/O -AJAIB SINGH	Female	Bachelor of Computer Application/BCA / 1Yr	Fresh	10	7000	7000	35728	0	35728	42728
4	676990	JASLEEN KAUR S/D/O -KULDEEP SINGH	Female	Bachelor of Computer Application/BCA / 1Yr	Fresh	10	7000	7000	35728	0	35728	42728
5	654467	JASMEEN KAUR S/D/O -CHAMKAUR SINGH	Female	Bachelor of Computer Application/BCA / 1Yr	Fresh	10	7000	7000	35728	0	35728	42728
5	950663	TARANPREET KAUR S/D/O -TEJINDER SINGH	Female	Bachelor of Computer Application/BCA / 1Yr	Fresh	10	7000	7000	35728	0	35728	42728
*	717411	HARPREET KAUR S/D/O -SURINDER SINGH	Female	Bachelor of Computer Application/BCA / 1Yr	Fresh	10	7000	7000	35728	0	35728	42728
1	632505	JASHANPREET KAUR S/D/O -MANJIT SINGH	Female	Bachelor of Computer Application/BCA / 1Yr	Fresh	10	7000	7000	35728	0	35728	42728
	770236	RUPA RANI S/D/O -BABU RAM	Female	Bachelor of Computer Application/BCA / 1Yr	Fresh	10	7000	7000	35728	0	35728	42728
*	800561	DALJEET KAUR S/D/O -KULWINDER SINGH	Female	Bachelor of Computer Application/BCA / 1Yr	Fresh	10	7000	7000	35728	0	35728	42728
	750733	MUSKAN GILL S/D/O -JAGDISH SINGH	Female	B.A./B.A / 1Yr	Fresh	10	3000	3000	18496	0	18496	21496

# Dr. Ambedkar

Scholarship Portal  
by  
Punjab Government

Government of Punjab Social Justice & Empowerment Department Sanction Order

Date : 11-Mar-2024

52	917877	SIMRANJIT KAUR S/D/O -JAGTAR SINGH	Female	B.A./B.A / 1Yr	Fresh	10	3000	3000	18496	0	18496	21496
53	691889	JASPREET KAUR S/D/O -GURSAX SINGH	Female	B.A./B.A / 1Yr	Fresh	10	3000	3000	18496	0	18496	21496
54	586392	JASMEEN KAUR S/D/O -SHAVINDER SINGH	Female	B.A./B.A / 1Yr	Fresh	10	3000	3000	18496	0	18496	21496
55	669168	KULJIT KAUR S/D/O -GURDIAL SINGH	Female	B.A./B.A / 1Yr	Fresh	10	3000	3000	18496	0	18496	21496
56	628008	BALWINDER KAUR S/D/O -BHAGWAN SINGH	Female	B.A./B.A / 1Yr	Fresh	10	3000	3000	18496	0	18496	21496
57	652185	SURINDER KAUR S/D/O -PAPPU SINGH	Female	B.A./B.A / 1Yr	Fresh	10	3000	3000	18496	0	18496	21496
58	711302	SIMRANJIT KAUR S/D/O -HARJINDER SINGH	Female	B. Com./B.Com / 1Yr	Fresh	10	3000	3000	10898	0	10898	13898
59	925702	PAWANDEEP KAUR S/D/O -JAGMOHAN SINGH	Female	B. Com./B.Com / 1Yr	Fresh	10	3000	3000	10898	0	10898	13898
60	930134	POOJA S/D/O -GURMEET SINGH	Female	B. Com./B.Com / 1Yr	Fresh	10	3000	3000	10898	0	10898	13898
61	917681	SEEMA RANI S/D/O -NAND KISORE	Female	B. Com./B.Com / 1Yr	Fresh	10	3000	3000	10898	0	10898	13898
62	922393	HARMANJOT KAUR S/D/O -MANJINDER SINGH	Female	B. Com./B.Com / 1Yr	Fresh	10	3000	3000	10898	0	10898	13898
63	925603	HARPREET KAUR S/D/O -GURPREET SINGH	Female	B. Com./B.Com / 1Yr	Fresh	10	3000	3000	10898	0	10898	13898
64	929830	ALKA S/D/O -GURDEV SAGAR	Female	B. Com./B.Com / 1Yr	Fresh	10	3000	3000	10898	0	10898	13898
65	917268	PRIYANKA S/D/O -RANJIT KUMAR	Female	B. Com./B.Com / 1Yr	Fresh	10	3000	3000	10898	0	10898	13898
66	676516	ARSHPREET KAUR S/D/O -NARINDER SINGH	Female	B. Com./B.Com / 1Yr	Fresh	10	3000	3000	10898	0	10898	13898



**KHALSA COLLEGE FOR WOMEN SIDHWAN KHURD (LUDHIANA)**

**FEE CONCESSION SESSION 2022-23**

**STUDENT AID FUND**

Sr No	Name	Class	Roll No	Amount	Cheque No.	Signature
1	JASPREET KAUR	BAI	1	850	592774 29.05.23	Jaspreet Kaur
2	GAGANDEEP KAUR	BAI	2	1650	592775 29.05.23	Gagandeep Kaur
3	RAMANDEEP KAUR	BAI	3	1650	592776 29.05.23	Ramandeep Kaur
4	SUKHMANDEEP KAUR	BAI	5	850	New Ch. No 910434 Dt. 10.11.23 592779 29.05.23	Sukhmandeep Kaur
5	GAGANDEEP KAUR	BAI	6	850	592779 29.05.23	Gagandeep Kaur
6	HARMANJOT KAUR	BAI	8	850	592784 29.05.23	Harmanjot Kaur
7	PRABHMINDER KAUR	BAI	10	1650	New Ch. No 910433 Dt. 10.11.23 592781 29.05.23	Prabhminder Kaur
8	KIRAN KAUR	BAI	13	1650	592782 29.05.23	Kiran Kaur
9	RAMANPREET KAUR	BAI	14	1650	592783 29.05.23	Ramanpreet Kaur
10	PALWINDER KAUR	BAI	15	1650	592785 29.05.23	Palwinder Kaur
11	INDERVEER KAUR	BAI	16	850	New Ch. No 910436 Dt. 10.11.23 592786 29.05.23	Inderveer Kaur
12	JASPREET KAUR	BAI	18	1650	592787 29.05.23	
13	GURNEET KAUR	BAI	23	1650	592788 29.05.23	Gurneet Kaur
14	KOMALPREET KAUR	BAI	25	850	592790 29.05.23	Komalpreet Kaur
15	MANVEER KAUR	BAI	26	1650	592791 29.05.23	Manveer Kaur
16	SUKHDEEP KAUR	BAI	27	1650	592792 29.05.23	Sukhdeep Kaur
17	SIMRANDEEP KAUR	BAI	30	850	New Ch. No 910437 Dt. 10.11.23 592793 29.05.23	Simrandeep Kaur
18	PRABHJOT KAUR	BAI	32	850	New Ch. No 910438 Dt. 10.11.23 592794 29.05.23	Prabhjot Kaur
19	SUKHDEEP KAUR	BAI	34	850	592795 29.05.23	Sukhdeep Kaur
20	ANMOL KAUR	BAI	44	1650	New Ch. No 910439 Dt. 10.11.23 592796 29.05.23	Anmol Kaur
21	PAWANPREET KAUR	BAI	46	1650	592797 29.05.23	Pawanpreet Kaur
22	GURWINDER KAUR	BCA I	1001	2000	New Ch. No 910460 Dt. 10.11.23 592798 29.05.23	Gurwinder Kaur
23	HARPREET KAUR	BCAI	1003	2000	592799 29.05.23	
24	MANDEEP KAUR	BCAI	1006	2000	New Ch. No 910461 Dt. 10.11.23 592800 29.05.23	Mandeep Kaur
25	GURMEET KAUR	BSC-I	1302	1000	592801 29.05.23	

**KHALSA COLLEGE FOR WOMEN SIDHWAN KHURD (LUDHIANA)**

**FEE CONCESSION SESSION 2022-23**

**STUDENT AID FUND**

Sr. No	Name	Class	Roll No	Amount	Cheque No.	Signature
26	JASPREET KAUR	BSC-I	1303	2050	892807 29.05.23	
27	MUSKANPREET	BSC I (NON-MED)	1401	2000	892804 29.05.23	Muskanpreet Kaur
28	KOMALPREET KAUR	BSC I (NON-MED)	1404	1000	892803 29.05.23	
29	SANDEEP KUAR	BSC I (NON-MED)	1405	1000	892806 29.05.23	Sandeep Kaur
30	SUBHANGI KUMARI	BSC I (NON-MED)	1408	3000	892801 29.05.23	Subhangi Kumari
31	SIMRANJEET KAUR	BCOM-I	1901	2750	892808 29.05.23	Simranjeet Kaur
32	AMRITPAL KAUR	BCOM-I	1902	1350	892809 29.05.23	Amritpal Kaur
33	SUKHMANPREET Kaur	BCOM-I	1903	1350	892810 29.05.23	Sukhmanpreet Kaur
34	HARPREET KAUR	BCOM-I	1908	2750	892811 29.05.23	
35	AMANDEEP KAUR	BCOM-I <small>New Ch. No 910902 21.10.11.23</small>	1912	1350	892812 29.05.23	Amandeep Kaur
36	RAMANPREET KAUR	BCOM-I	1914	2750	892813 29.05.23	Ramanpreet Kaur
37	KIRAMDEEP KAUR	BCOM-I	1916	1350	892814 29.05.23	Kiramdeep Kaur
38	RAMANDEEP KAUR	BCOM-I <small>New Ch. No 910903 21.10.11.23</small>	1920	2750	892815 29.05.23	Ramandeep Kaur
39	KOMALPREET KAUR	BCOM-I	1924	2750	892816 29.05.23	Komalpreet Kaur
40	AMANPREET KAUR	BCOM-I	1925	1350	892817 29.05.23	
41	MALLIKA THAKUR	BA/BED-I <small>New Ch. No. 910904 21.10.11.23</small>	2202	2700	892818 29.05.23	Mallika Thakur
42	ARSHDEEP KAUR	BA/BED-I <small>New Ch. No. 910905 21.10.11.23</small>	2205	2700	892819 29.05.23	Arshdeep Kaur
43	RAJINDER KAUR	MCOM-I	3401	1350	892820 29.05.23	Rajinder Kaur
44	MANPREET KAUR	MCOM-I	3403	1350	897701 29.05.23	Manpreet Kaur
<b>TOTAL-----</b>				<b>72100</b>		

DATED : 24.05.2023

**Fee Committee**

- 1 Dr Navdip Kaur
- 2 Dr Iqbaljit Kaur
- 3 Dr Gagandeep Dharmi
- 4 Prof Inderjit Kaur
- 5 Prof Harwinder kaur
- 6 Mrs Baldev Kaur Mann

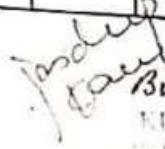
  
 PRINCIPAL  
 KHALSA COLLEGE FOR WOMEN  
 SIDHWAN KHURD (LUDHIANA)

72100  
 (100 Left Students) 11800





**Khalsa College for Women Sidhwan Khurd (Ludhiana)**

**FEE CONCESSION SESSION 2022-23**

**STUDENT SCHOLARSHIP FUND**

Sr No	Name	Class	Roll No	Amount	Cheque NO	Signature
1	RAJDEEP KAUR	BAI	7	2500	892763 29.05.23	Rajdeep Kaur
2	MUSKAAN KAUR	BAI	12	2500	892764 29.05.23	Muskan Kaur
3	KAMALPREET KAUR New Ch. No. 910950 Dt. 10.11.23	BAI	22	2500	892765 29.05.23	Kamalpreet Kaur
4	HARSHDEEP KAUR	BAI	33	2500	892766 29.05.23	Harshdeep Kaur
5	MANVEER KAUR New Ch. No. 910951 Dt. 10.11.23	BCAI	1009	6000	892767 29.05.23	Manveer Kaur
6	NAVJOT KAUR	BCAI	1010	6000	892768 29.05.23	Navjot Kaur
7	RAMANDEEP KAUR New Ch. No. 910952 Dt. 10.11.23	BCAI	1013	6000	892769 29.05.23	Ramandeep Kaur
8	RAMANPREET KAUR	BSCI (Non-Med.)-1	1407	3000	892770 29.05.23	!!
9	RUPINDER KAUR	B.COM I	1909	4100	892771 29.05.23	Rupinder Kaur
10	MANPREET KAUR	B.COM I	1913	4100	892772 29.05.23	Manpreet Kaur
11	RIYA SINGLA New Ch. No. 910953 Dt. 10.11.23	BA/B.ED-I	2206	4050	892773 29.05.23	Riya Singh
<b>TOTAL-----</b>				<b>43250</b>		

DATED : 24.05.2023

  
 Jandeep Kaur  
 Bursar  
  
 PRINCIPAL  
 Khalsa College for Women,  
 Sidhwan Khurd (Ludhiana)

**Fee Committee**

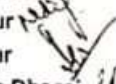
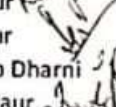
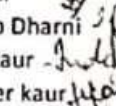
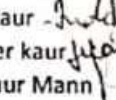
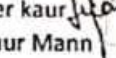
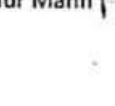
- 1 Dr Navdip Kaur 
- 2 Dr Iqbaljit Kaur 
- 3 Dr Gagandeep Dharni 
- 4 Prof Inderjit Kaur 
- 5 Prof Harwinder kaur 
- 6 Mrs Baldev Kaur Mann 

Less 10%  
(Student)

43250

38000

45250



Waheguruji ka Khalsa,  
Waheguruji ki Fateh!

In continuation to our earlier e-mail intimating you about grant of SHDF scholarship, we are pleased to intimate you that you have been granted a scholarship of **Rs. 24000/-**.

**The scholarship cheque will be presented to you in a Programme as per schedule given below:**

Centre	Date & reporting time	Venue	Contact Person(s) for reaching the venue
Ludhiana	16/3/2024, 9.00 am	Ramgarhia girls college, Vishkarma Main Road, Near Vishkarma Chowk, Miller Ganj, Ludhiana, Punjab 141003	S. Jasvinder Singh - 9872536035, S. Kulwinder Singh - 7355148983

Waheguruji ka Khalsa,  
Waheguruji ki Fateh!

We are pleased to intimate you that you have been granted SHDF scholarship of Rs. 31000/-.

**The scholarship cheque will be presented to you in a Programme as per schedule given below:**

Centre	Date & reporting time	Venue	Contact Person(s) reaching for the venue
Faridkot, Bathinda, Sri Muktsar Sahib, Talwandi Sabo	16/3/2024, 9 00 am	Akal University, Near Professor Colony, Raman Road, Talwandi Sabo.	S. Harjeet Singh - 8437221325 S. Prabhjot Singh - 9814900645

Please make it convenient to attend the Programme along with your parents. For any other query please contact at 011-28333842/ 7827384938

With best wishes  
Scholarship Division

**Important Note: The students must bring their Identification proof e.g. Admit Card or College / Institute identity card.**



to me ▾

Dear GURPREET KAUR(Roll No.-  
20231045, Phone No.- 6284649025,  
CENTRE-LUDHIANA)

Waheguruji ka Khalsa,  
Waheguruji ki Fateh!

We are pleased to intimate you that you  
have been granted scholarship of **Rs.  
24000/-**.

**The scholarship cheque will be  
presented to you in a Programme as  
per schedule given below:**

Centre	Date & reporting time	Venue	Contact Person(s) reaching for the venue
Ludhiana & Chandigarh	12/5/2024, 9.00 am	Auditorium, Guru Nanak Dev Engineering College, Ludhiana	S. Jasvinder Singh - 9872536035

Please make it convenient to attend the  
Programme along with your parents.  
For any other query please contact at



Reply





## ਖ਼ਾਲਸਾ ਕਾਲਜ ਫ਼ਾਰ ਵਿਮੈਨ, ਸਿੱਧਵਾਂ ਖੁਰਦ (ਲੁਧਿਆਣਾ)

### ਸੂਚਨਾ

ਸਮੂਹ ਵਿਦਿਆਰਥੀਆਂ ਨੂੰ ਸੂਚਿਤ ਕੀਤਾ ਜਾਂਦਾ ਹੈ ਕਿ ਪੰਜਾਬ ਸਰਕਾਰ ਵੱਲੋਂ ਸੈਸ਼ਨ 2023-24 ਲਈ ਸਮੂਹ SC/OBC ਵਿਦਿਆਰਥੀਆਂ ਲਈ ਪੋਸਟ ਮੈਟ੍ਰਿਕ ਸਕਾਲਰਸ਼ਿਪ ਭਰਨੀ ਸ਼ੁਰੂ ਕਰ ਦਿੱਤੀ ਗਈ ਹੈ। ਵਿਦਿਆਰਥੀ ਕਿਸੇ ਵੀ ਇੰਟਰਨੈੱਟ ਕੈਫੇ ਤੋਂ ਸਕਾਲਰਸ਼ਿਪ ਅਪਲਾਈ ਕਰ ਸਕਦਾ ਹੈ। ਸਕਾਲਰਸ਼ਿਪ ਭਰਨ ਉਪਰੰਤ ਹੇਠ ਲਿਖੇ ਦਸਤਾਵੇਜ਼ ਫਾਰਮ ਨਾਲ ਨੱਥੀ ਕਰਕੇ ਕਾਲਜ ਦਫ਼ਤਰ ਵਿਚ (2 ਸੈੱਟ) ਜੁਮਾਂ ਕਰਵਾਉਣੇ ਯਕੀਨੀ ਬਣਾਏ ਜਾਣ। ਕਿਸੇ ਵੀ ਵਿਦਿਆਰਥੀਆਂ ਦਾ ਅਧੂਰਾ ਫਾਰਮ ਜਮ੍ਹਾਂ ਨਹੀਂ ਕੀਤਾ ਜਾਵੇਗਾ। ਫਾਰਮ ਜਮ੍ਹਾਂ ਨਾ ਹੋਣ ਲਈ ਵਿਦਿਆਰਥੀ ਖੁਦ ਜਿੰਮੇਵਾਰ ਹੋਵੇਗਾ।

### Documents Required (ਜ਼ਰੂਰੀ ਲੋੜੀਂਦੇ ਦਸਤਾਵੇਜ਼):

1. ਸਕਾਲਰਸ਼ਿਪ ਅਪਲਾਈ ਕੀਤੇ ਫਾਰਮ ਦਾ ਪ੍ਰਿੰਟਆਊਟ।
2. ਵਿਦਿਆਰਥੀ ਦੀ ਪਾਸਪੋਰਟ ਸਾਈਜ਼ ਫੋਟੋ।
3. ਵਿਦਿਆਰਥੀ ਦੇ ਜਾਤੀ (SC/OBC) ਸਰਟੀਫਿਕੇਟ ਦੀ ਕਾਪੀ।
4. ਵਿਦਿਆਰਥੀ ਦੇ ਪਿਤਾ ਦਾ ਆਮਦਨ ਸਰਟੀਫਿਕੇਟ।
  - SC 2,50,000/- ਅਤੇ OBC 1,00,000/- ਤੋਂ ਘੱਟ ਹੋਵੇ।
  - ਆਮਦਨ ਸਰਟੀਫਿਕੇਟ ਮੌਜੂਦਾ ਸੈਸ਼ਨ 2023-24 ਦਾ ਹੋਵੇ।
  - ਆਮਦਨ ਸਰਟੀਫਿਕੇਟ ਤਹਿਸੀਲਦਾਰ ਵੱਲੋਂ ਬਣਿਆ ਹੋਵੇ। (ਅਸਲੀ ਕਾਪੀ/Original Copy)
  - ਆਮਦਨ ਐਫੀਡੇਵਿਟ ਨਹੀਂ ਮੰਨਿਆ ਜਾਵੇਗਾ।
5. ਵਿਦਿਆਰਥੀ ਦੇ ਬੈਂਕ ਖਾਤੇ ਦੀ ਪਾਸ ਬੁੱਕ ਦੇ ਪਹਿਲੇ ਪੇਜ ਦੀ ਕਾਪੀ।
  - ਬੈਂਕ ਖਾਤਾ ਵਿਦਿਆਰਥੀ ਦੇ ਨਾਮ ਤੇ ਹੋਵੇ।
  - ਬੈਂਕ ਖਾਤਾ ਐਕਟੀਵੇਟ (ਚਾਲੂ) ਹੋਵੇ।
  - ਅਕਾਊਂਟ ਨੰਬਰ ਅਤੇ IFSC Code ਦਰੁੱਸਤ ਹੋਵੇ ਅਤੇ ਪਾਸ ਬੁੱਕ ਤੇ ਲਿਖਿਆ ਚੰਗੀ ਤਰ੍ਹਾਂ ਨਜ਼ਰ ਆਉਂਦਾ ਹੋਵੇ।
  - ਵਿਦਿਆਰਥੀ ਦਾ ਅਕਾਊਂਟ ਨੰਬਰ ਆਧਾਰ ਨੰਬਰ ਨਾਲ ਲਿੰਕ ਹੋਣਾ ਲਾਜ਼ਮੀ ਹੈ।
6. ਪਿਛਲੀਆਂ ਪਾਸ ਕੀਤੀਆਂ ਕਲਾਸਾਂ ਦੇ ਸਰਟੀਫਿਕੇਟ। (ਦਸਵੀਂ ਤੋਂ ਸਾਰੇ)
7. ਵਿਦਿਆਰਥੀ, ਵਿਦਿਆਰਥੀ ਦੇ ਪਿਤਾ ਅਤੇ ਮਾਤਾ ਦੇ ਆਧਾਰ ਕਾਰਡਾਂ ਦੀ ਕਾਪੀ।
8. ਵਿਦਿਆਰਥੀ ਦਾ ਹਲਫ਼ੀਆਂ ਬਿਆਨ (Student Undertaking) ਨੋਟਰੀ ਤੋਂ ਤਸਦੀਕ ਹੋਵੇ।
9. ਰਿਹਾਇਸ਼ੀ (Residence) ਸਰਟੀਫਿਕੇਟ (ਤਿੰਨ ਸਾਲ ਤੋਂ ਪੁਰਾਣਾ ਨਹੀਂ ਮੰਨਿਆ ਜਾਵੇਗਾ)।
10. ਫਰੀਸ਼ਿਪ ਕਾਰਡ ਦੀ ਕਾਪੀ (ਸਾਰੇ UG/PG ਕੋਰਸਾਂ ਦੇ ਕੇਵਲ ਪਹਿਲੇ ਸਾਲਾਂ ਦੇ SC ਵਿਦਿਆਰਥੀਆਂ ਲਈ)

### ਜ਼ਰੂਰੀ ਹਦਾਇਤਾਂ:

1. ਸਕਾਲਰਸ਼ਿਪ ਪੰਜਾਬ ਸਰਕਾਰ ਦੇ ਪੋਰਟਲ [www.scholarships.punjab.gov.in](http://www.scholarships.punjab.gov.in) ਤੇ ਅਪਲਾਈ ਹੋਵੇਗੀ।
2. ਇੱਕ ਵਿਦਿਆਰਥੀ ਇੱਕ ਸੈਸ਼ਨ ਵਿਚ ਕੇਵਲ ਇੱਕ ਹੀ ਸਕਾਲਰਸ਼ਿਪ ਅਪਲਾਈ ਕਰ ਸਕਦਾ ਹੈ, ਇਸ ਲਈ ਜੇਕਰ ਕਿਸੇ ਵਿਦਿਆਰਥੀ ਨੇ ਕੋਈ ਹੋਰ ਸਕਾਲਰਸ਼ਿਪ ਅਪਲਾਈ ਕੀਤੀ ਹੈ ਤਾਂ ਉਹ ਇਹ ਸਕਾਲਰਸ਼ਿਪ ਨਹੀਂ ਭਰ ਸਕਦਾ।
3. ਵਿਦਿਆਰਥੀਆਂ ਵੱਲੋਂ ਸਕਾਲਰਸ਼ਿਪ ਲਈ ਦਿੱਤਾ ਜਾਣ ਵਾਲਾ ਆਪਣਾ ਫੋਨ ਨੰਬਰ ਸਹੀ ਹੋਵੇ।
4. ਜੇਕਰ ਸਕਾਲਰਸ਼ਿਪ ਭਰਨ ਵਿਚ ਕਿਸੇ ਵੀ ਵਿਦਿਆਰਥੀ ਨੂੰ ਕੋਈ ਸਮੱਸਿਆ ਆ ਰਹੀ ਹੈ ਜਾਂ ਕੋਈ ਵਧੇਰੇ ਜਾਣਕਾਰੀ ਲੈਣੀ ਹੋਵੇ ਤਾਂ ਉਹ ਹੇਠ ਲਿਖੇ ਸਟਾਫ਼ ਮੈਂਬਰਾਂ ਨੂੰ ਕਾਲਜ ਆ ਕੇ ਮਿਲ ਸਕਦੇ ਹਨ ਜਾਂ ਹੇਠ ਲਿਖੇ ਫੋਨ ਨੰਬਰਾਂ ਤੇ ਸੰਪਰਕ ਕਰ ਸਕਦੇ ਹਨ।
  - ਪ੍ਰੋ. ਹਰਦੀਪ ਕੌਰ (ਇੰਚਾਰਜ SC/OBC ਸਕਾਲਰਸ਼ਿਪ) - 83600-60890
  - ਸ. ਜਗਰਾਜ ਸਿੰਘ (ਡੀਲਿੰਗ SC/OBC ਸਕਾਲਰਸ਼ਿਪ) - 96535-42285
  - ਕਾਲਜ ਦਫ਼ਤਰ - 01624-234967

ਮਿਤੀ 08.09.2023

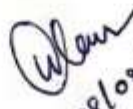
  
08/09/2023

  
Principal  
Khalsa College for Women,  
Sidhwan Khurd (Ludhiana)

## DR.B.R SCHOLARSHIP STUDENTS LIST SESSION- 2022-23

### SC Fresh ( Total-43 Students)

SR.NO	ID NO	NAME	FATHER NAME	CLASS	ROLL NO
1	548285	Ashwinder Kaur	Parminder Singh	MA-I ENG	3003
2	456256	Rajinder Kaur	Harbans Singh	M.Com-I	3401
3	506137	Gagandeep Kaur	Gurpreet Singh	BA.B.Ed-I	2208
4	510839	Jaspreet Kaur	Kewal Singh	B.Sc-I (Med)	1303
5	836962	Gurmeet Kaur	Jagroop Singh	B.Sc-I (Med)	1302
6	590776	Radika	Sunil Kumar	B.Sc-I(N.Med)	1402
7	655805	Muskanpreet Kaur	Balvir Singh	B.Sc(N.Med)-I	1401
8	600589	Arshdeep Kaur	Balvir Singh	B.Sc(N.Med)-I	1403
9	831091	Kaishleen Kaur	Jatinder Singh	BCA-I	1012
10	473720	Ramandeep Kaur	Paramjeet Singh	BCA-I	1013
11	542893	ManveerKaur	Kuldeep Singh	BCA-I	1009
12	837106	Harpreet Kaur	Jagdev Singh	BCA-I	1003
13	551884	Harpreet Kaur	Lal Singh	B.Com-I	1908
14	885416	Amandeep Kaur	Satpal Singh	B.Com-I	1912
15	824879	Pranhjot Kaur	Buta Singh	B.Com-I	1922
16	466958	Sukhpreet Kaur	Jinder Singh	B.Com-I	1918
17	506167	Ramnjoy Kaur	Achhru Singh	B.Com-I	1926
18	447744	Komalpreet Kaur	Jagshir Singh	B.Com-I	1924
19	485678	Jaspreet Kaur	Palwinder Singh	BA-I	18
20	569308	Komalpreet Kaur	Resham Singh	BA-I	25
21	584919	Gagandeep Kaur	Sukhwinder Singh	BA-I	2
22	505762	Anmol Kaur	Gurcharan Singh	BA-I	44
23	595308	Pranhjot Kaur	Gurcharan Singh	BA-I	32
24	761605	Sandeep Kaur	Kuldeep Singh	BA-I	41
25	845643	Sukhdeep Kaur	Jagtar Singh	BA-I	34
26	850373	Rajdeep Kaur	Hakam Singh	BA-I	7
27	852824	Harshdeep Kaur	Sukhwinder Singh	BA-I	33
28	878051	Jaspreet Kaur	Gurmeet Singh	BA-I	21
29	614599	Arshdeep Kaur	Jagtar Singh	BA-I	28
30	748416	Simrandeep Kaur	Chamkaur Singh	BA-I	30
31	853652	Gagandeep Kaur	Ajit Singh	BA-I	6
32	870697	Sukhmandeep Kaur	Jagtar Singh	BA-I	5
33	479404	Sandeep Kaur	Kashmir Singh	BA-I	45
34	836418	Ramandeep Kaur	Kulwant Singh	BA-I	3
35	845944	Mantej Kaur	Tirah Singh	BA-I	24
36	866109	Kiran Kaur	Bhajan Singh	BA-I	13
37	849783	Rajwant Kaur	Jasvir Singh	BA-I	19
38	831799	Deepika Rani	Barkar Singh	BA-I	20
39	575268	Jaspreet Kaur	Jaswant Singh	BA-I	1
40	673701	Harmanpreet Kaur	Sukhminder Singh	BA-I	40
41	865210	Harpreet Kaur	Jagsir Singh	BA-I	42
42	871410	Sandeep Kaur	Jagdev Singh	B.Sc(N.Med)-I	1405
43	891903	Pawanpreet Kaur	Gurcharan Singh	BA-I	46

  
**Principal,**  
**Khalsa College for Women,**  
**Sidhwan Khurd (Ludhiana)**



# College Alumni

## Our Alumni - Our Pride



Mrs. Anjali Kaur (1987-88 Batch)

Member of Parliament, South West England, Cambridge



Mrs. Rajinder Kaur Shastri (1985-86 Batch)

First Woman Chief Minister of Punjab



Mrs. Jashinder Kaur (1990-91 Batch)

Principal, Sikh Girls Sr. Sec. School, Sidhwan Khurd



Dr. Kuljit Kaur Chahal (1987-91)

Associate Professor, GNDU, Amritsar



Ms. Princy Kaur (1986-87 Batch)

Educator, Mississauga, Ontario, Canada



Mrs. Kamaljit Kaur (1988-89 Batch)

Teacher, Sikh Girls Sr. Sec. School, Sidhwan Khurd



Dr. Simranpreet Kaur (1984-85)

Asst. Prof. Jashwanthi, Mandi, Jammu



Mrs. Sangeet Kaur (1988-89 Batch)

Principal, GGS Nathwal School, Dabba



Mrs. Rajinder Kaur (1987-88)

Teacher in Punjab, Govt S.S. School



Mrs. Rajinder Kaur (1984-85)

Teacher, Govt. Sr. Sec. School, Faridkot



Google

GPS Map Camera

Sidhwan Khurd, Punjab, India  
RHH3+2JG, Sidhwan Khurd Link Rd, Sidhwan Khurd, Punjab 142024, India  
Lat 30.827466°  
Long 75.553936°  
12/12/23 09:49 AM GMT +05:30

**Progression of Students for higher studies during the session 2022-23**



A student ID card for Tanveer Hans. The card features a portrait of a woman wearing a grey headscarf on the left. To the right, the name 'Chisholm' is written in a blue cursive font, with 'STUDENT' in bold black capital letters below it. The student number 'No: s202411048' is printed in black. A blue decorative graphic is on the right side. At the bottom, a barcode is followed by the name 'Tanveer Hans', the year 'Year 23 24 25', and the alphanumeric code 'X2024110487'.

**Chisholm**  
**STUDENT**  
No:  
s202411048

**Tanveer Hans**

Year  
23 24 25

X2024110487

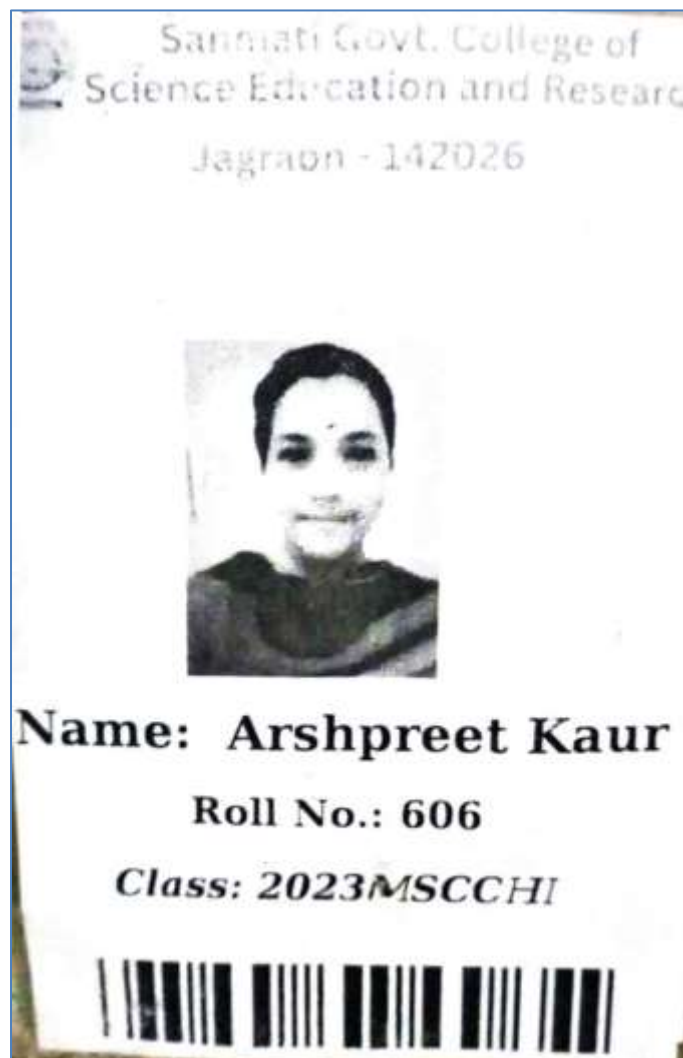

A student ID card for Arshpreet Kaur. The card features a portrait of a woman in a dark top. At the top, the text reads 'Sannati Govt. College of Science Education and Research' and 'Jagraon - 142026'. Below the portrait, the name 'Name: Arshpreet Kaur' is printed in bold, followed by 'Roll No.: 606' and 'Class: 2023MSCCHI'. A barcode is located at the bottom of the card.

Sannati Govt. College of  
Science Education and Research  
Jagraon - 142026

**Name: Arshpreet Kaur**  
**Roll No.: 606**  
**Class: 2023MSCCHI**



# Best Practice II

## Eco-Friendly Environment

### 1. Solid Waste Management



Separate bins for different types of waste



Aerobic Composting System



# Vermi composting







### Anaerobic Composting System



Compost prepared from the Anaerobic System



**Furnace outside the campus**





Sidhwan Khurd, Punjab, India  
Rhh2+34x, Sidhwan Kalan Sidhwan Khurd Link Rd, Sidhwan  
Khurd, Punjab 142024, India  
Lat 30.826793° Long 75.551672°  
02/12/24 11:47 AM GMT +05:30

## Segregation area earmarked for Trash

# Liquid Waste Management

## 1. Water Recharge System

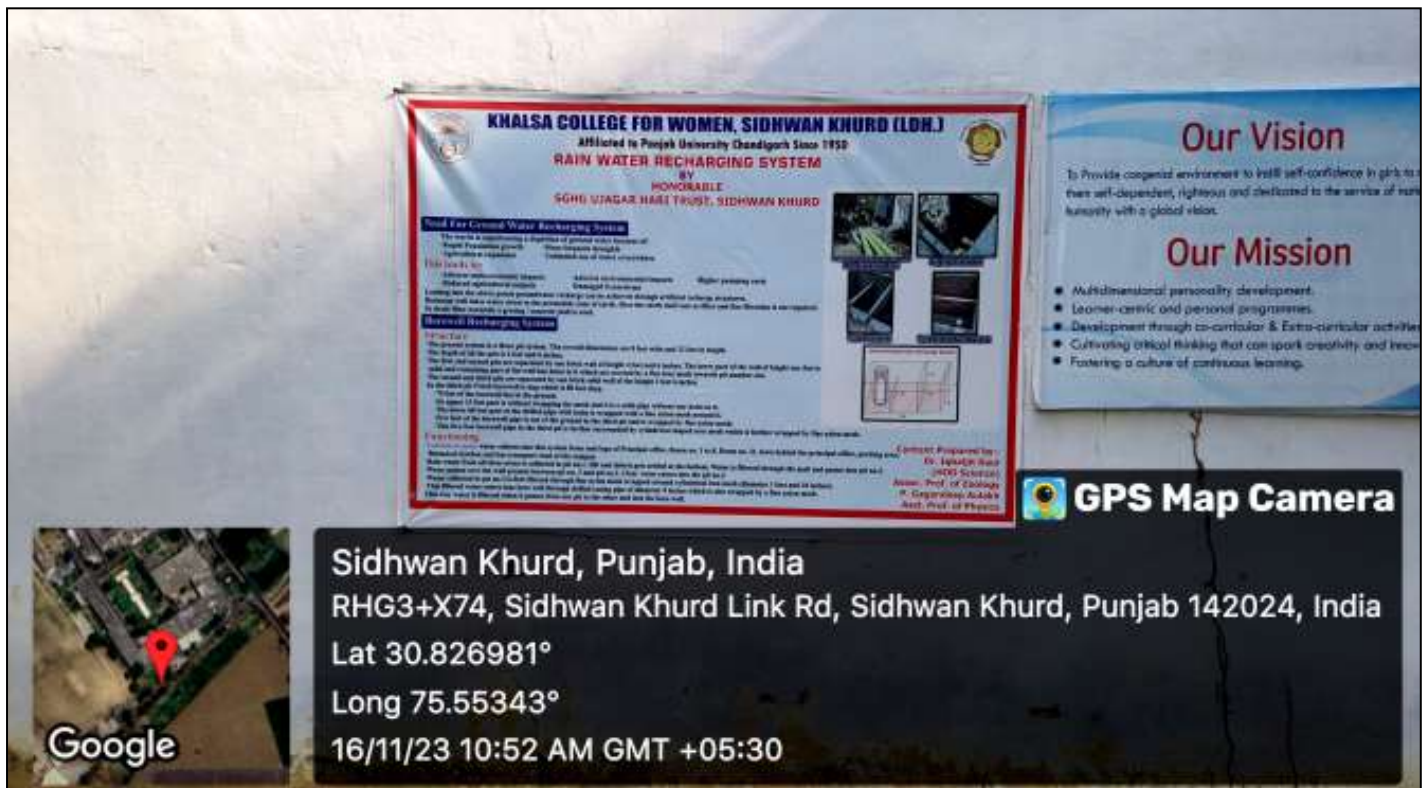



## Borewell Rainwater Recharge System

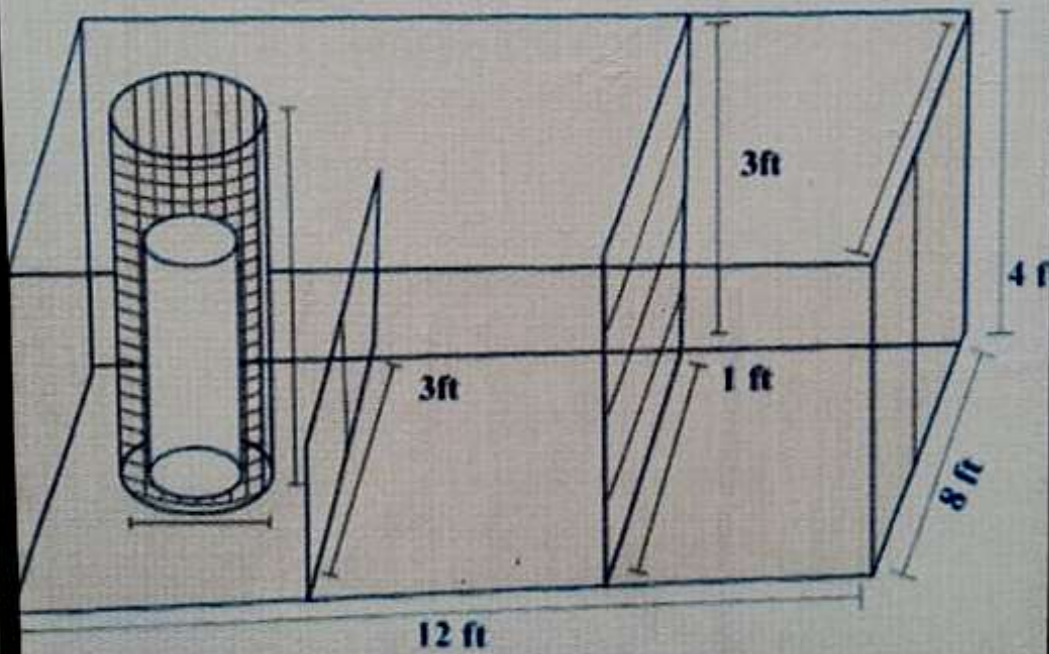

## 2. Rain Water Reuse in Lawns





### 3. Maintenance of Water Bodies, Drainage System, Fountains and Sprinklers.



**Khalsa College for Women,  
Sidhwan Khurd, Ludhiana**

**ENVIRONMENT  
AUDIT REPORT  
(2023– 24)**



# **1. INTRODUCTION**

The environmental audit aims to evaluate and analyze the environmental practices both within and surrounding the college campus. It involves a systematic process of identifying, quantifying, documenting, reporting, and analyzing various components of the institutional environment. Through the environment audit, the institution seeks to identify areas for improvement, develop strategies for sustainable growth, and create a roadmap for fostering an environmentally responsible culture.

## **1.1 NEED FOR ENVIRONMENT AUDITING**

An environmental audit is an essential tool for evaluating and enhancing the sustainability practices of any institution. Its need arises from the growing emphasis on environmental conservation and sustainable development. It serves as a vital tool for assessing the environmental impact of activities, ensuring compliance with legal regulations and promoting eco-friendly practices. By systematically evaluating resource usage, waste management, and pollution levels, an environmental audit identifies inefficiencies and provides actionable recommendations for improvement. It also raises awareness among stakeholders about the importance of conservation and sustainable development. Ultimately, an environmental audit supports long-term ecological balance, cost-effective resource management, and the creation of a healthier environment for future generations.

## **1.2 GOALS OF ENVIRONMENT AUDIT**

The college has conducted an environment audit with specific goals such as:

1. To evaluate the existing environmental practices within the campus and their impact on sustainability.
2. Identify and implement efficient strategies for utilization of resources such as energy and water.
3. Enhance effective waste management systems including segregation and proper disposal.
4. To identify environmental risks and implement measures to mitigate them.
5. To educate and involves students in sustainable practices and conservation practices.
6. To contribute to global sustainability efforts and set benchmarks for continuous improvement.

7. To enhance the green cover, biodiversity and ecological balance within the campus.
8. To identify and reduce sources of air, water and noise pollution generated by campus activities.

## **2. OBJECTIVES AND SCOPE**

The broad aims/benefits of the eco auditing system would be

- Environment education through systematic environmental management approach.
- Enhancing environmental standards for a sustainable future.
- Establishing benchmarks for sustainable environmental practices.
- Optimizing resource consumption for a greener campus.
- Maximizing savings by lowering resource usage.
- Fostering practical knowledge for academic excellence.
- Empowering students with ownership and responsibility for campus sustainability.
- Elevating the college standing through environmental and social responsibility.
- Cultivating sustainable values in youth for a greener future.



**Khalsa College for Women,  
Sidhwan Khurd, Ludhiana**

**GREEN  
AUDIT  
REPORT  
(2023 – 24)**

## **INTRODUCTION:**

Green Audit is the process of assessing the environmental impact of an organization, process, project, or procedure. It involves systematic identification, quantification, recording, reporting and analyzing of the environmental practices within and outside of the concerned institution which impact the eco-friendly ambience of the college. Assessing the environmental impact of a college through green audit can help it to take stock of its existing environment of components and help in making changes, chalking out future strategies for improvement and promoting awareness regarding green practices.

### **Objectives of Green Audit:**

1. To assess and preserve the biodiversity of the college by systematically documenting its flora and fauna.
  2. To document the environmental ambience and ecological characteristics of the institution.
  3. To ensure the environmental compliance by documenting the waste disposal strategies adopted by the institution.
  4. To evaluate and document the methods used for maintaining water quality and preventing wastage.
  5. To document initiatives undertaken to raise awareness among stakeholders about green practices and sustainability.
  6. To document energy efficiency of the institution.
-



## Methodology of Green Audit

The methodology of the green audit includes collection of data along with physical verification, Observation and assessment of the institution's strengths/weakness through data findings and analysis.

### 1. Floral Diversity of the Campus

<b>CAMPUS FLORA</b>					
<b>Sr.No</b>	<b>Common Name</b>	<b>Botanical Name</b>	<b>Family</b>	<b>Locality</b>	<b>Number</b>
1	Amla	<i>Emblica</i>	Phyllanthaceae	Botanical Garden	2
2	Areca Palm	<i>Dyopsis lutescens</i>	Arecaceae	Bebe Ram Kaur Park	5
3	Arjun	<i>Terminalia arjuna</i>	Combretaceae	Botanical Garden	1
4	Arrow Head	<i>Syngonium</i>	Araceae	Fountain lawn	11
				Principal office (Back side)	7
				Front gate (Left side)	45
5	Ashoka	<i>Saraca</i>	Fabaceae	Fountain lawn	22
				Bebe Ram Kaur Park	17
				Botanical Garden	4
				Front gate (Left side)	2
6	Bakul	<i>Mimusops elengi</i>	Sapotaceae	Fountain lawn	1
7	Bamboo	<i>Bambusa vulgaris</i>	Poaceae	Fountain lawn	5
8	Banana	<i>Musa acuminata</i>	Musaceae	Library back side	1
9	Beach Spider Lily	<i>Hymenocallis</i>	Amaryllidaceae	Main gate Park	1
10	Bengal Kino	<i>Butea monosperma</i>	Fabaceae	Library back side	1
11	Black Poui	<i>Jacaranda</i>	Bignoniaceae	Principal office (Back side)	1
12	Black Walnut	<i>Juglans regia</i>	Juglandaceae	Botanical Garden	1
13	Blackwood Acacia	<i>Acacia</i>	Fabaceae	Fountain lawn	2
14	Bottle Brush	<i>Callistemon</i>	Myrtaceae	Fountain lawn	6
15	Century plant	<i>Agave</i>	Asparagaceae	Principal office (Back side)	2
16	Chir Pine	<i>Pinus</i>	Pinaceae	Botanical Garden	2
17	China Rose	<i>Hibiscus</i>	Malvaceae	Bank side garden	3
				Fountain lawn	11
				Bebe Ram Kaur Park	19
				Botanical Garden	6
				Principal office (Back side)	2
				Main gate Park	3
				Law College Road	3
18	Common Fig	<i>Ficus carica</i>		Principal office (Back side)	2
19	Common Juniper	<i>Juniperus</i>	Cupressaceae	Main gate Park	3
				Fountain lawn	1
20	Corn plant	<i>Dracaena</i>	Dracaenaceae	Front gate (Left side)	24
				Bank side garden	10
				Bebe Ram Kaur Park	14
21	Crepe Jasmine / Chandni	<i>Tabernaemontana</i>	Apocynaceae	Fountain lawn	28

				Botanical Garden	7
22	Croton	<i>Codiaeum</i>	Euphorbiaceae	Principal office (Back side)	4
23	Curry Leaves	<i>Murraya koenigii</i>	Rutaceae	Library back side	1
				Principal office (Back side)	1
				Fountain lawn	2
				Principal Residence	1
24	Cypress (Thuja)	<i>Cupressus</i>	Cupressaceae	Main gate Park	3
				Fountain lawn	28
				Botanical Garden	1
25	Dek	<i>Melia azadirachta</i>	Meliaceae	Fountain lawn	1
				Bebe Ram Kaur Park	1
				Law College Road	3
26	Devil Tree	<i>Alstonia</i>	Apocynaceae	Bank side garden	2
				Fountain lawn	7
				Botanical Garden	1
				Lawn Behind Chemistry Lab	1
27	Donkey Ears / Bryophyllum	<i>Kalanchoe</i>	Crassulaceae	Principal office (Back side)	1
28	Dwarf Powder	<i>Colliandra tergemina</i>	Fabaceae	Front gate	3
29	Figworts	<i>Leucophyllum</i>	Scrophulariaceae	Principal office (Back side)	4
30	Fish Tail Palm	<i>Caryota</i>	Arecaceae	Botanical Garden	1
31	Fire Bush	<i>Hamelia patens</i>	Rubiaceae	Bank side garden	1
				Fountain lawn	2
32	Giriba Palm	<i>Syagrus romanzoffiana</i>	Arecaceae	Bebe Ram Kaur Park	1
33	Golden shower plant	<i>Cassia fistula</i>	Fabaceae	Law College Road	2
				Botanical Garden	1
				Law College Road	3
				Principal office (Back side)	1
34	Gular	<i>Ficus racemosa</i>	Moraceae	Library back side	3
35	Holy Basil	<i>Ocimum</i>	Labiatae	Main gate park	8
				Principal office (Back side)	2
36	Indian Beech	<i>Pongamia</i>	Fabaceae	Library back side	1
				Fountain lawn	4
				Botanical Garden	1
37	Jackfruit / Kathal	<i>Artocarpus</i>	Artocarpaceae	Bank side garden	1
38	Jamun	<i>Syzygium</i>	Myrtaceae	Botanical Garden	1
				Principal office (Back side)	1
39	Kanak Champa	<i>Pterospermum acerifolium</i>	Malvaceae	Library back side	1
40	Keli	<i>Canna</i>	Cannaceae	Main gate Park	4
41	Lemon	<i>Citrus limon</i>	Rutaceae	Bebe Ram Kaur Park	3
				Library back side	12
				Alongside Main gate	1
42	Locust Tree	<i>Ceratonia siliqua</i>	Fabaceae	Botanical Garden	4
				Library back side	1
43	Loquat	<i>Eriobotrya</i>	Rosaceae	Botanical Garden	2
44	Mahua	<i>Madhuca longifolia</i>	Sapotaceae	Botanical Garden	1



45	Mango	<i>Mangifera</i>	Anacardiaceae	Bank side garden	4
				Botanical Garden	11
				Library back side	5
46	Mountain Rock Fig	<i>Ficus glumosa</i>	Moraceae	Fountain lawn	8
				Bebe Ram Kaur Park	27
				Lawn Behind Chemistry Lab	7
47	Mulberry	<i>Morus</i>	Moraceae	Fountain lawn	2
				Right hand side of Main gate	1
				Law College Road	2
48	Neem	<i>Azadirachta indica</i>	Meliaceae	Law College Road	3
				Principal office (Back side)	1
49	Nerium	<i>Cascabela thevetia</i>	Apocynaceae	Bebe Ram Kaur Park	1
50	Oleander	<i>Thevetia</i>	Apocynaceae	Fountain lawn	4
				Law College Road	3
51	Plum	<i>Prunus</i>	Rosaceae	Botanical Garden	2
52	Pigeon Berry	<i>Duranta</i>	Verbenaceae	Main gate Park	51
				Fountain lawn	385
				Front corner of main gate	40
53	Pony tail palm	<i>Beaucarnea</i>	Asparagaceae	Main gate park	2
				Front corner of main gate	1
54	Rangoon creeper / jhumka Bael	<i>Combretum</i>	Combretaceae	Botanical Garden	3
55	Rose	<i>Rosa</i>	Rosaceae	Bank side garden	15
				Fountain lawn	11
				Bebe Ram Kaur Park	9
				Principal office (Back side)	6
56	Rose moss	<i>Portulaca grandiflora</i>	Portulacaceae	Principal office (Back side)	1
57	Sago palm	<i>Cycas</i>	Cycadaceae	Principal office (Back side)	3
				Principal office (Back side)	1
58	Senna plant	<i>Senna corymbosa</i>	Fabaceae	Botanical Garden	2
59	Silver Cock / Cockscomb	<i>Celosia argentia</i>	Amaranthaceae	Principal office (Back side)	8
60	Silver oak	<i>Grevillea</i>	Proteaceae	Fountain lawn	1
61	Soapnuts / Ritha	<i>Sapindus mukorossi</i>	Sapindaceae	Library back side	1
				Law College Road	10
62	Spurge	<i>Euphorbia</i>	Euphorbiaceae	Principal office (Back side)	12
63	Tahli	<i>Dalbergia sisoo</i>	Fabaceae	Law College Road	3
64	Thorn Apple	<i>Datura innoxia</i>	Solanaceae	Library back side	2
65	Water lily	<i>Nymphaea</i>	Nymphaeaceae	Botanical Garden (Pond)	1
66	Waterthyme	<i>Hydrilla</i>	Hydrocharitaceae	Botanical Garden (Pond)	1
67	Weeping Fig	<i>Ficus benjamina</i>	Moraceae	Main gate Park	2
68	White Fig	<i>Ficus virens</i>	Moraceae	Library back side	1
69	Willow Tree	<i>Salix</i>	Salicaceae	Botanical Garden	1
				Total	1057

## 2. Faunal diversity of the Campus

Sr. No	Zoological Name	Common Name	Phylum	Order
1	<i>Panoguina errans</i>	Wanderings skipper	Arthropoda	Lepidoptera
2	<i>Apis</i>	Honey bee	Arthropoda	Hymenoptera
3	<i>Zizekria</i>	Butterfly	Arthropoda	Lapidoptera
4	<i>Bradinapyga</i>	Dragon fly	Arthropoda	Odonata
5	<i>Danaus chrysippus</i>	Tiger butterfly	Arthropoda	Lapidoptera
6	<i>Epirinus</i>	Dung beetle	Arthropoda	Coleoptera
7	<i>Paratrechina</i>	Black ant	Arthropoda	Hymenoptera
8	<i>Tabanus</i>	Lady horse fly	Arthropoda	Diptera
9	<i>Schistocerca</i>	Grass hopper	Arthropoda	Orthoptera
10	<i>Isoptera</i>	Termite	Arthropoda	Blattodea
11	<i>Daphnis nerri</i>	Oleander hawk moth	Arthropoda	Lapidoptera
12	<i>Murgantia</i>	Harlequin bug	Arthropoda	Heteroptera
13	<i>Coccinellidae</i>	Lady bug	Arthropoda	Coleoptera
14	<i>Polistes watti</i>	Yellow wasp	Arthropoda	Hymenoptera
15	<i>Araniella cucurbitina</i>	Cucumber spider	Arthropoda	Araneae
16	<i>Poecilotheria</i>	Indian ornamental tree spider	Arthropoda	Araneae
17	<i>Pholcus</i>	Cellar spider	Arthropoda	Araneae
18	<i>Oncopeltus</i>	Milk weed bug	Arthropoda	Hemiptera
19	<i>Leclercqia</i>	Square head wasp	Arthropoda	Hymenoptera
20	<i>Polistes</i>	Paper wasp	Arthropoda	Hymenoptera
21	<i>Halyomorpha</i>	Stink bug	Arthropoda	Hemiptera
22	<i>Aplexa</i>	Moss blader snail	Mollusca	Gastropods
23	<i>Cirrhinus cirrhosus</i>	Marigal Carp	Chordata	Actinopterygii
24	<i>Pelophylax</i>	Water frog	Chordata	Amphibia
25	<i>Hemidictylus</i>	Domestic Wall lizard	Chordata	Reptila
26	<i>Calotes</i>	Garden lizard	Chordata	Reptilia
27	<i>Varanus</i>	Bengal monitor	Chordata	Reptilia

		lizard		
28	<i>Naja</i>	Cobra	Chordata	Reptilia
29	<i>Cyclodina</i>	Copper skink	Chordata	Reptilia
30	<i>Sphenomorphus</i>	arana	chordata	Reptilia
31	<i>Columba livia domestica</i>	Domestic pegin	Chordata	Aves
32	<i>Vanellus indicus</i>	Red watted lapwing	Chordata	Aves
33	<i>Pycnonotus</i>	Red vanted bul bul	Chordata	Aves
34	<i>Acridotheres tristis</i>	Common indian myna	Chordata	Aves
35	<i>Pendrocygn arborea</i>	Wishtling duck	Chordata	Aves
36	<i>Pasitlacula</i>	Parrot	Chordata	Aves
37	<i>Bubo</i>	Indian owl	Chordata	Aves
38	<i>Argya</i>	Jungle babbler	Chordata	Aves
39	<i>Passer domesticus</i>	House sparrow	Chordata	Aves
40	<i>Ardeidae</i>	Hérons	Chordata	Aves
41	<i>Upupa</i>	European hoopoe	Chordata	Aves
42	<i>Corvus</i>	Crow	Chordata	Aves
43	<i>Cercotrichas</i>	Black scrub robin	Chordata	Aves
44	<i>Cinnyris</i>	Purple sunbird	Chordata	Aves
45	<i>Centropus</i>	Greater coucal	Chordata	Aves
46	<i>Oenanthe</i>	Brown black chat	Chordata	Aves
47	<i>Treron phoenicopterus</i>	Yellow footed green pegin	Chordata	Aves
48	<i>Copsychus</i>	Oriental magpie Robin	Chordata	Aves
49	<i>Acridotheres ginginianus</i>	Bank myna	Chordata	Aves
50	<i>Streptopelia decaocta</i>	Eurasian collared dove	Chordata	Aves
51	<i>Arremonops chloronotus</i>	Green backed sparrow	Chordata	Aves
52	<i>Fanambulus</i>	Indian palm squirrel	Chordata	Mammalia
53	<i>Felis catus</i>	Indian domestic cat	Chordata	Mammalia
54	<i>Canis lupus</i>	Indian dog	Chordata	Mammalia



## II. Environmental Ambience of the Institution:

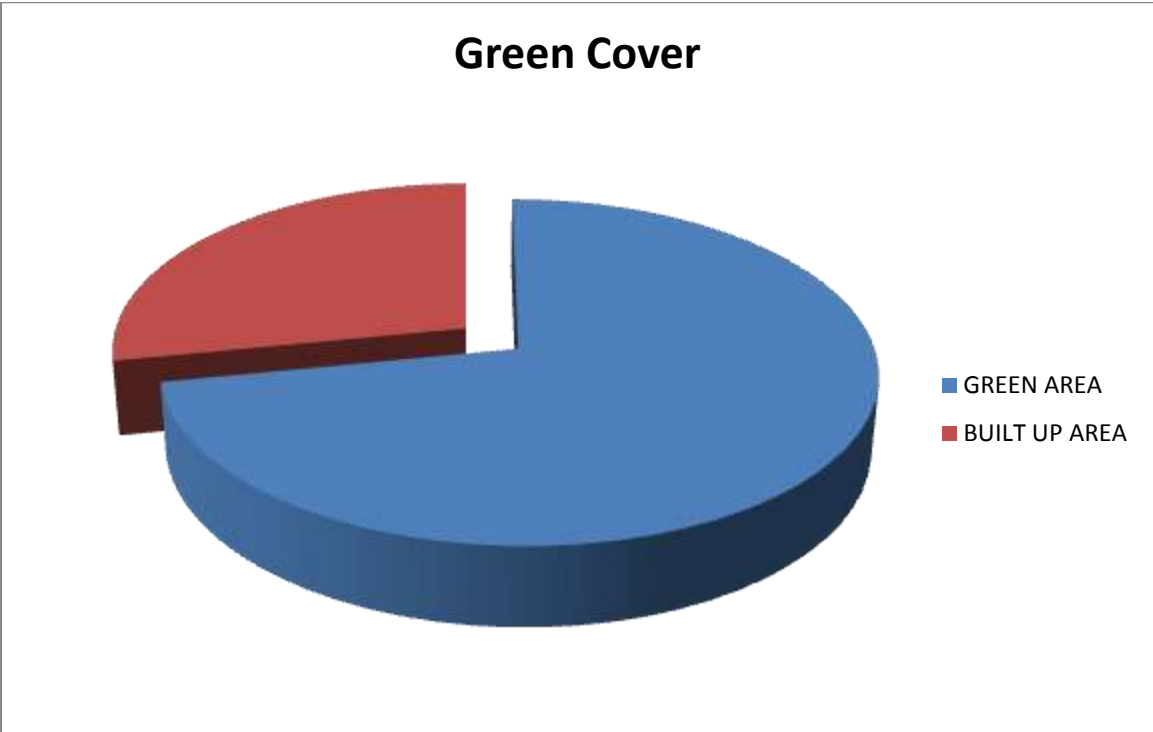

Total Green Area 60.64%









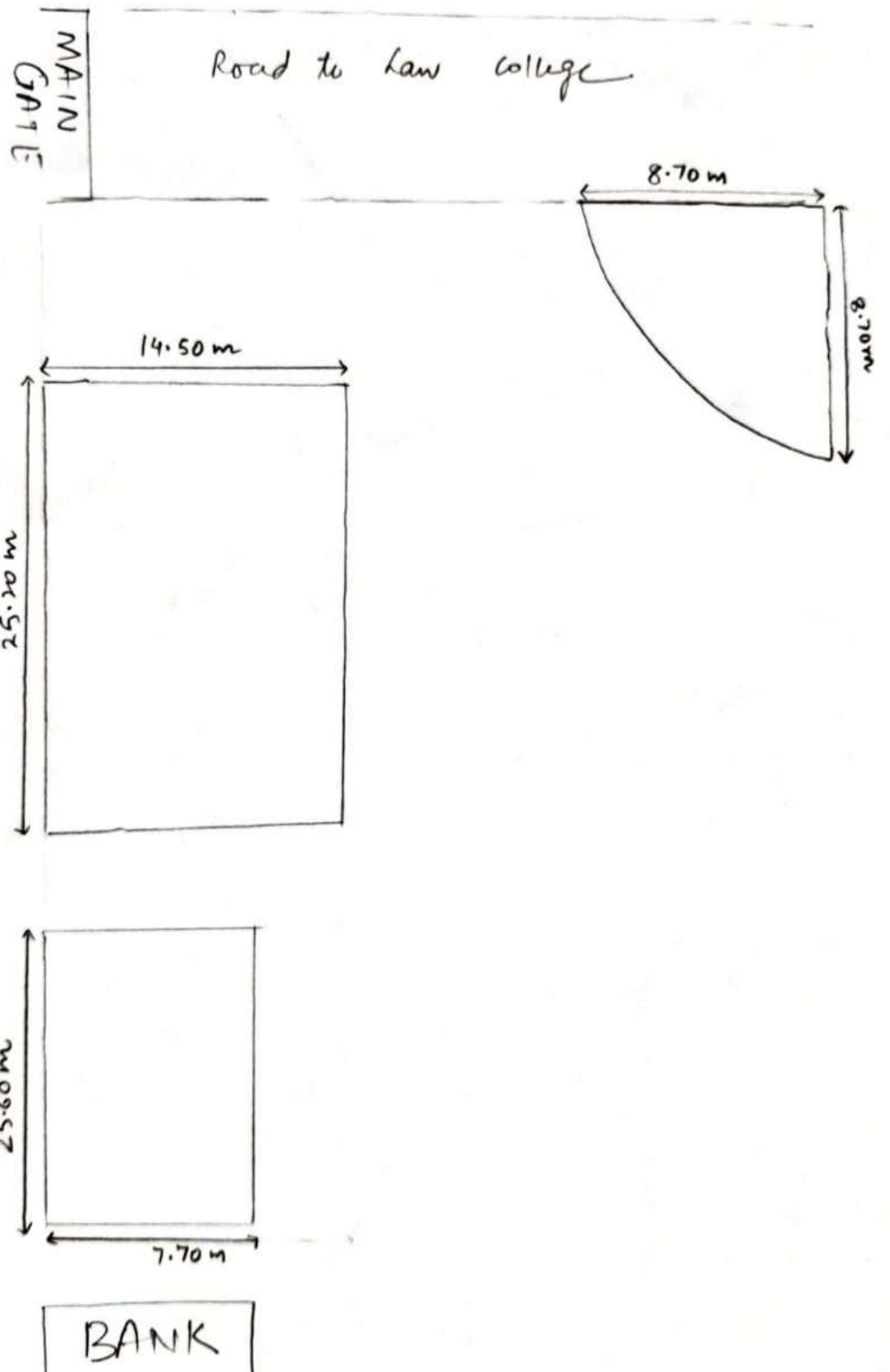

Road to law college

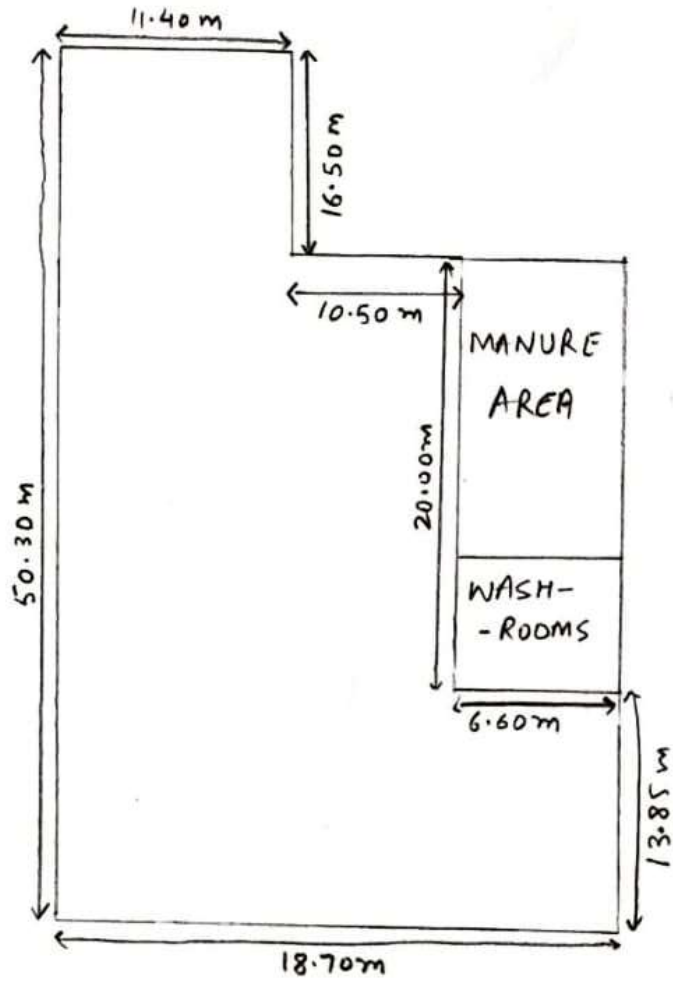

Parking area

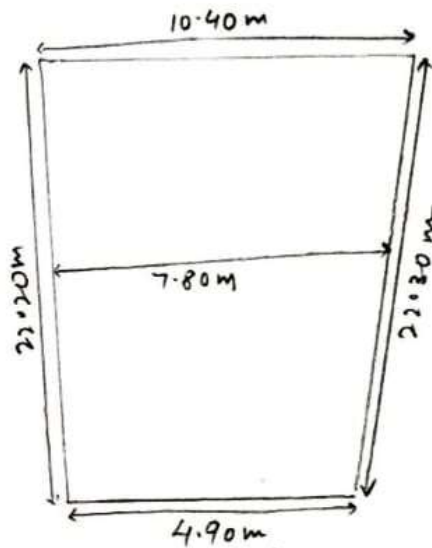

Principal office



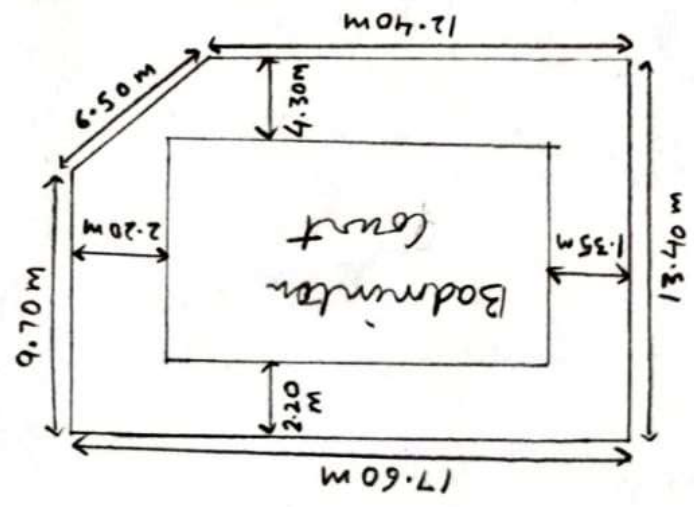
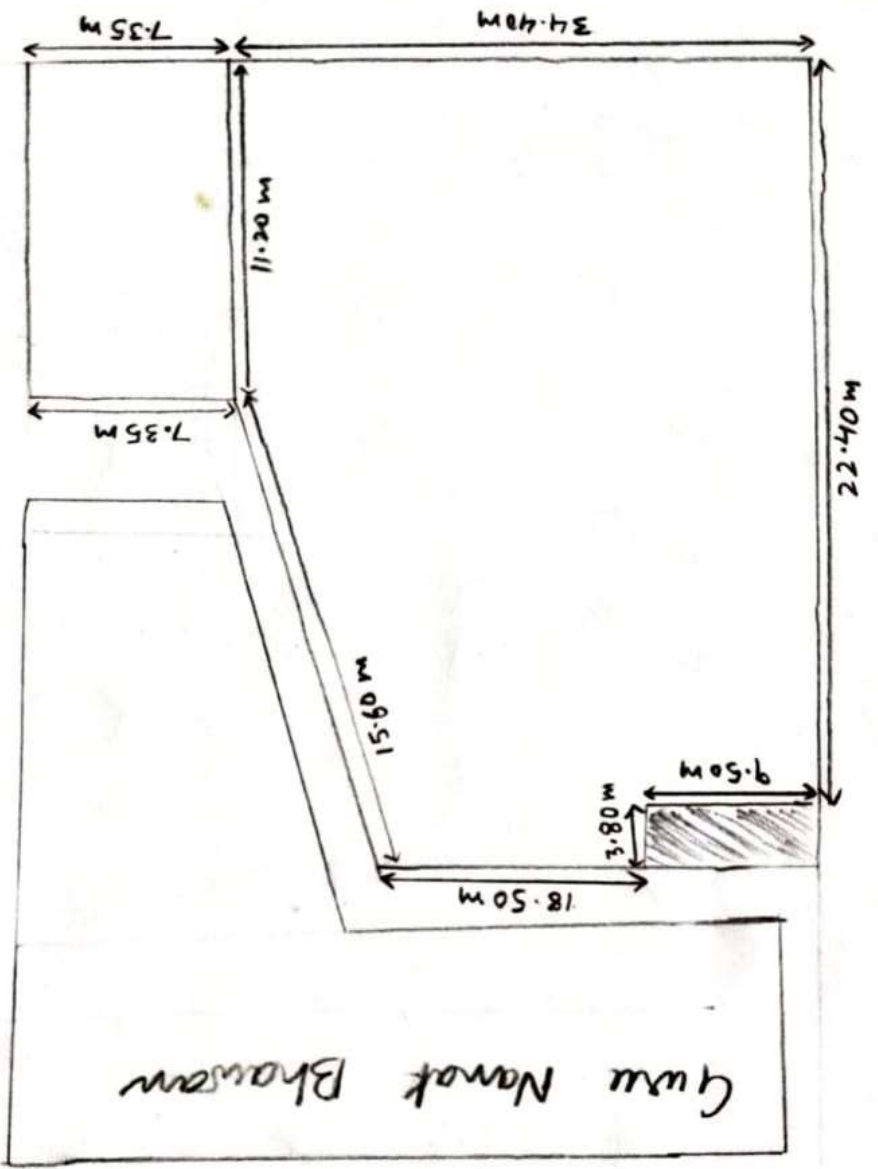

Chemistry Lab.

GURU NANAK BHAWAN

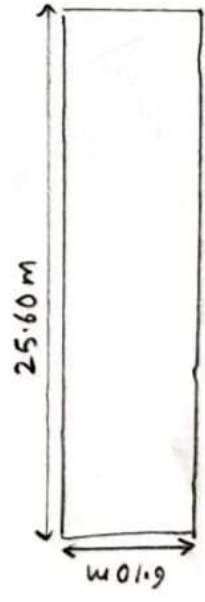
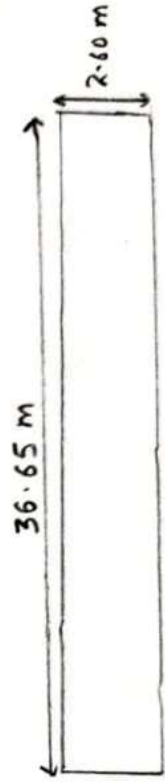
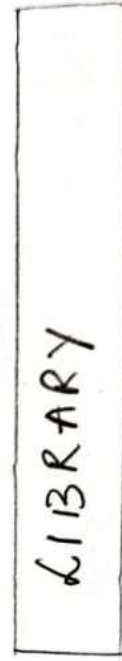
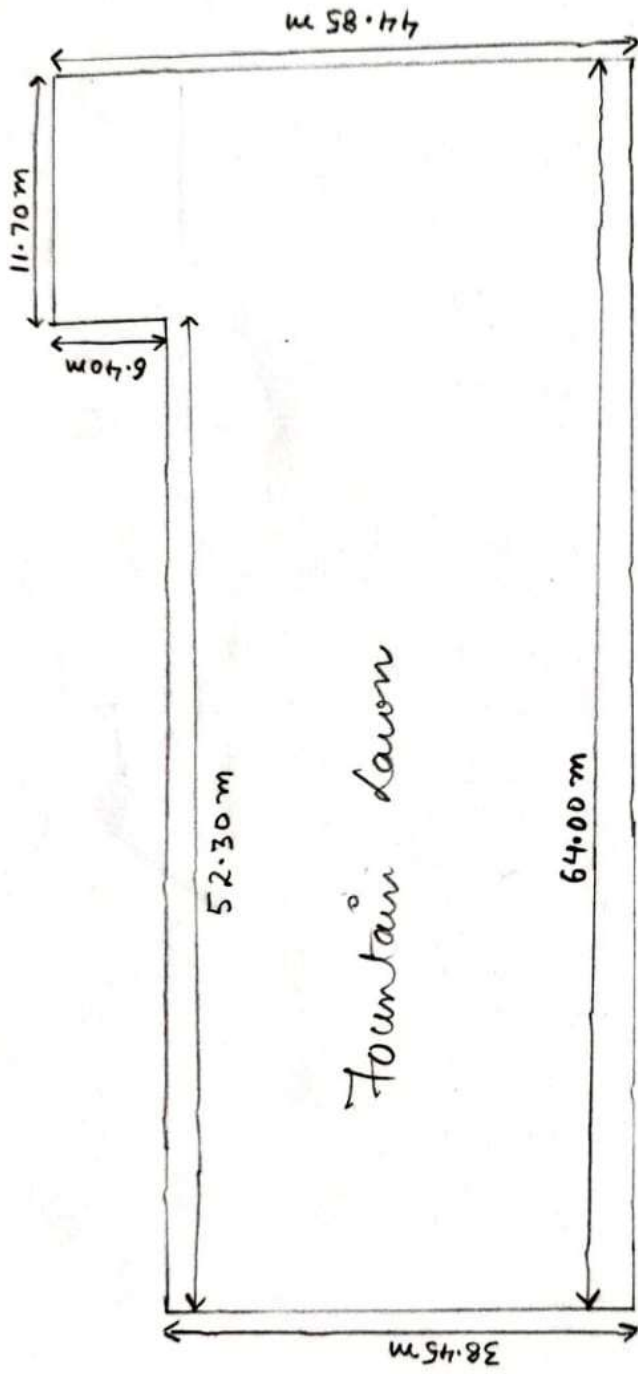

GROUND

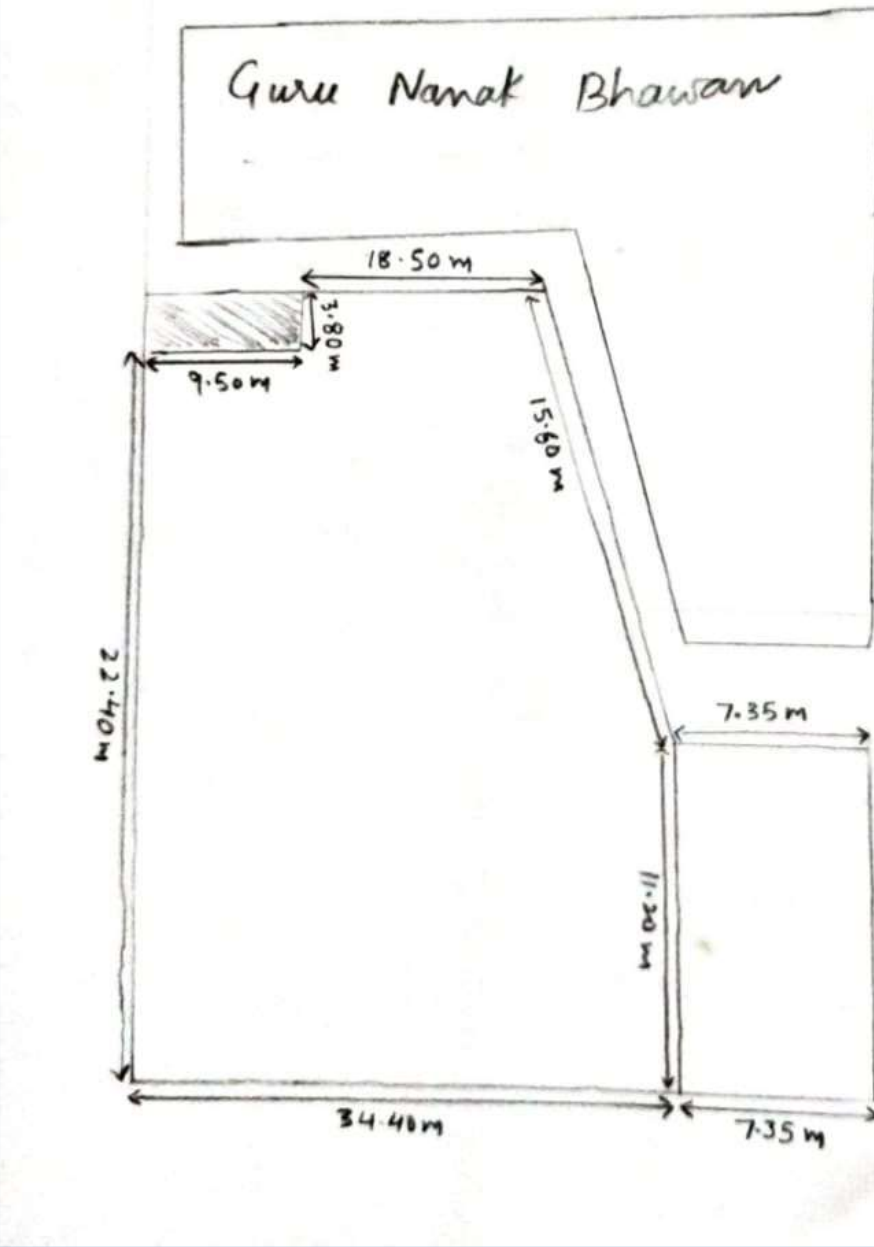
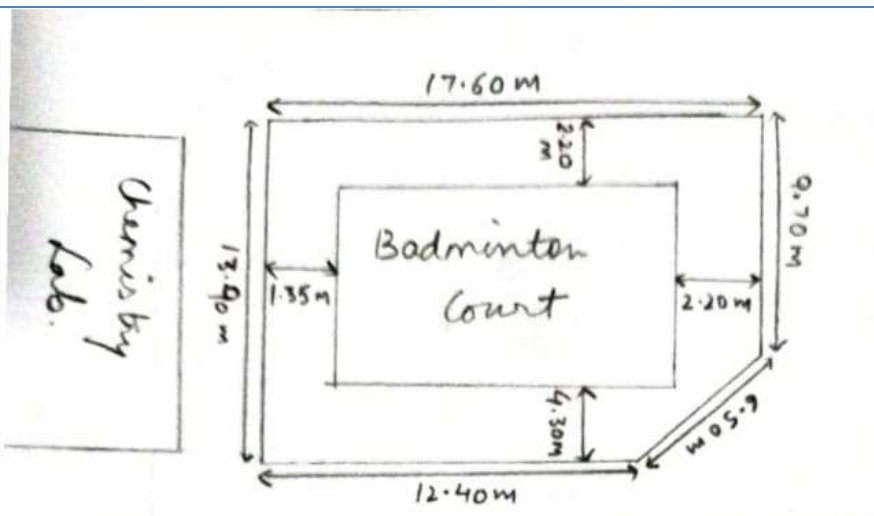





Steel  
Gate

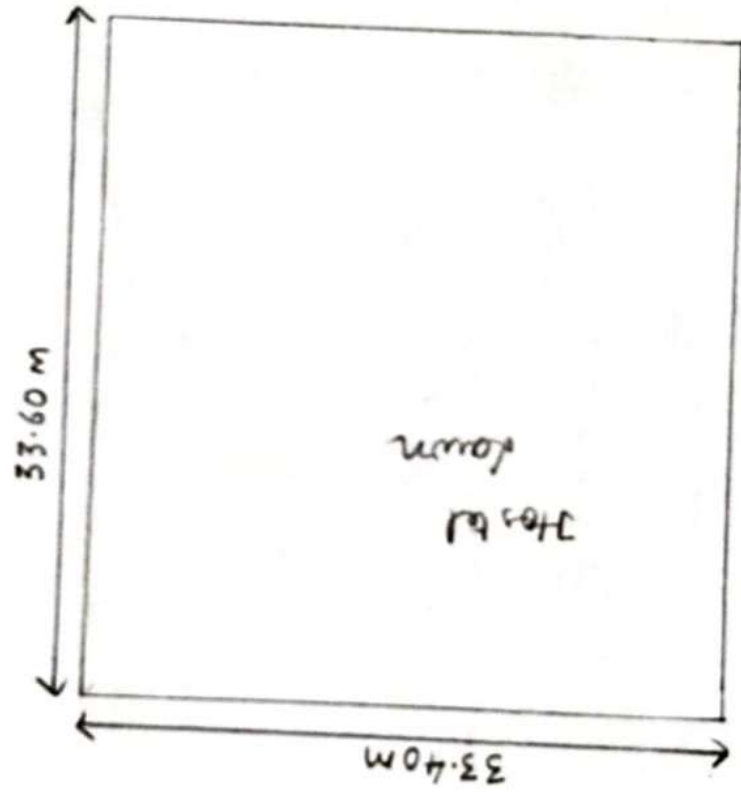

The college classrooms are airy and well lighted and hardly need any artificial Lighting. The building lay-out facilitates optimum use of day light and proper ventilation. The college lawns and playground of the college is full of floral and faunal diversity. The Botanical Garden has an aquarium that houses floral and faunal species. The institution is a 'Tobacco Free Zone.' Signage proclaiming the same has been displayed across the campus to ensure awareness.

Air quality is maintained as majority of staff and students commute by college buses or public transport. The institution is situated in lush green environment in rural region. No wood is burnt in cooking practice. Burning of dried leaves and wooden twigs are not allowed in the campus.

Divyang friendly barrier free environment for disabled is ensured. Ramps with Handrails for easy access to classrooms, tactile path, wheelchair, signage and lights have been provided.

- Pedestrian friendly roads are available in the institution.
- Fire extinguishers have been installed as safety measures.



- Maintenance of building and lawns is done by committees like Building committee, Infrastructure committee, Physical Audit committee, Gardening Club.
- In-house facility of plumber and electrician is available.
- Separate bins are used to manage segregated waste.
- On campus and off campus parking facility is provided. Organic farming, anaerobic and aerobic composting of leaves has been initiated.
- Provision of acoustics in Guru Nanak Bhawan (Auditorium) checks noise pollution.
- Artificial bird nests have been installed.

### **III. Waste Management**

- Solid Waste Management: Solid waste is segregated as biodegradable and non-biodegradable. Separate bins are used for collection. Dry leaves are thrown into the composting pits and converted into manure.
- Non-biodegradable waste is segregated. Separate zone has been marked to collect it. It is taken away by the junk dealers.
- The college is a no plastic zone.

**Liquid waste Management:** The rain water collected on rooftops is so managed so as to water the lawns through pipes. The water in the tank opposite Canteen lawn is reused in the lawn. Ground water recharge system has been installed. Sprinkles and fountains are installed.

**Hazardous Waste Management:** Inventory of chemicals is prepared and stock Register is maintained to record usage of chemicals. Panjab University, Chandigarh curriculum prescribes negligible number of chemicals that are hazardous. Separate bins have been provided for the same in the laboratories.

**E-Waste Management:** E-Waste generated in the college is very less in quantity. The Cartridges of laser-printers are re-filled outside the college campus. The E-Waste in the form of redundant computers and accessories is being stored properly.

It was suggested that the computers and accessories should be sold for recycling or disposed off as per norms.

**Biomedical Waste Management:** The Panjab University Curriculum does not allow dissection of animals in practical work. The students and staff who need medical help are referred to Babe Ram Kaur

Charitable Hospital run by SGHU Hari Trust. There is a provision of incinerator outside the college campus; the ash is used as manure in the fields.

#### **IV. Water Management system is in place.**

Ground water recharge system has been installed. There is a proper maintenance of tanks and bunds. The tank in lawn opposite canteen is reused in the lawn through proper distribution system. Rain water from roof-tops is directed to lawns through water pipes. Staff and Students participate in Eco-friendly practices and sensitization Programmes.

Green initiatives are regularly undertaken by the staff and students. Plantation drives, landscaping and beautification of the campus is carried out. Activities related to environmental consciousness regarding stubble burning, water conservation plastic waste free campaign is conducted.

- Swachhta Hi Sewa is celebrated to inspire youth to contribute towards a cleaner and healthier environment. Community outreach through rallies and organization of awareness programs



on environmental issues is done. Sanitization and cleanliness as per standard operating procedure.

- Artificial bird nests are installed.
- Organic farming, anaerobic and aerobic composting of leaves has been initiated.
- Days of National and International importance related to environmental awareness like World Environment Day, World Water day and Red Ribbon Day.
- NSS Camp focuses on the theme “Sawachh Bharat & Meri Maati Mera Desh” was organized.

## **V. Energy efficiency of the institution**

- The Institution believes in "Energy Saved is Energy Produced". Wise appliance choices are made. Members of the staff have been deputed to check the wastage of electrical energy by ensuring that fans should not run in unoccupied laboratories and classrooms. Lights are switched off immediately when not required. Computers, Printers, copiers etc. which are not in use are closed down and disconnected at the end of day. Electronic gadgets and equipment are shut off during non-working hours.

All the office windows are covered by blinds or curtains to reduce heat conduction. In efforts to promote energy efficiency and sustainability, all air conditioning units across the campus have been set at 22° to 24°C. Split units and central ACs have been installed in the institution compatible to occupancy level.

**Khalsa College For Women, Sidhwan Khurd (Ludhiana)**

**Environment Audit Report**

**1) Water Audit**

Capacity of Main Water Tank – 28000 ltrs

Power of submersible motor – 15 hp

Total number of secondary water tanks at various buildings of college campus – 14

Total Water Filters – 07

Sr. no.	Location of Water Cooler	Capacity of Water Cooler in Ltrs
1.	Near Main Gate	80
2.	Near Auditorium	80
3.	College Hostel	80
4.	Near Transport office	40
5.	Near College Library	80
6.	On First Floor	20
7.	Gurudwara Sahib	40

Average Drinking Water consumption per day – 1000 ltrs

Average water consumption in college campus per day – 28000 ltrs

**2) Cleanliness and Sanitization of College Campus.**

a) Proper Hygiene is maintained at each and every place of the College Campus. Dustbins of different colours ( Blue, Green, Red) are put at various locations to separately store and dispose Biodegradable and Non-Biodegradable wastage.

b) Sanitization of college campus is done regularly. Standard Operating Procedures (SOP's) given by Central/State government from time to time to combat COVID-19 are strictly followed.

3) Are there energy saving methods employed in your college? Please specify.

Ans: - Yes (LED Bulbs)

4) Is there a committee to check energy wastage?

Ans: - Yes

A) Is Water conservation facility available?

Ans: - Yes (Ground water recharge system)

B) Is waste water management implemented?

Ans: - Yes

C) Does the institution have on the campus arrangements for Plumbing?

Ans: - Yes

D) Is the quality of drinking water checked?

Ans: - Yes

5) Is on the campus electrician available?

Ans: - Yes

**6) Is there a provision for the upkeep and maintenance of equipments?**

**Ans: - Yes (Trained lab Attendants, AMC with Company)**

**7) Are wise heating and cooling choices made?**

**Ans :- Yes**

**8) Is there a committee to maintain building and infrastructure?**

**Ans :- Yes**

**Building Committee**

**Physical Audit Committee**

**9) Are there parking facilities on/Off the campus?**

**Ans :- Yes**

**10) Building Plan that facilitates use of natural sunlight in Class rooms?**

**Ans :- Yes**

**11) Is barrier free environment and facilities provided to Divyaang. Please specify ?**

**Ans :- Yes.**

**Signage, Tactite Path, Lights, Ramps, Divyaang friendly washrooms, Wheelchair**

**12) Does the institution implements:**

**A) Pedestrian Friendly Pathways.**

**B) Landscaping with trees and plants.**

**C) Ban on use of plastic**

**D) Restricted entry of automobiles.**

**Ans :- Yes (All of the above )**

**13) Are fire safety measures provided?**

**Ans :- Yes**

**14) Is inventory of chemicals prepared?**

**Ans :- yes**

**15) Does the institution have an environmental policy?**

**Ans :- Yes**

**16) Is environmental policy displayed on the website?**

**Ans - Yes**

**17) Does the institution have waste management procedures in place?**

**Ans :- Yes.**

**18) Are on campus and off campus environmental awareness activities conducted?**

**Ans:- Yes**



**Khalsa College for Women,  
Sidhwan Khurd, Ludhiana**

**ENERGY  
AUDIT  
REPORT  
(2023 – 24)**

## **COLLEGE CAMPUS AREA**

### **(A)Basic**

**1.Source of Energy ; PSPCL through KWH meter No. X 0324248 .**

**1 A. Standby Supply;- The load is alternatively connected to DG set of 82.5/125 KVA**

**2.PSPCL account No; U22 GC 220016FS**

**3.Connected load;- 75.87 KW.**

**4.Location;- COLLEGE CAMPUS BUILDING.**

### **(B)Distribution**

**The energy is connected and distributed to different loads through**

**different sub distribution boards at all levels of the building by suitable and correct**

**Sizes of wire/ cables. Power factor is well maintained and is in specified limits**

### **(C) Safety**

**Satisfactory safety measures are being adopted by the consumer. All appliances, lighting fixture/ceiling/ exhaust fans are of BIS ratings and are in proper serviceable and working conditions. All light fixture are of LED type providing power factor close to unity with adequate lumens output.**

**All switch sockets are adequately protected from direct contact to live parts of switch boards**

**Earthing stations/pits are also provided and are found to be within permissible values**

## **COLLEGE HOSTEL BLOCK**

### **(A) Basic**

**1. Source of Energy ; PSPCL through KWH meter No. X 0323814 .**

**1 A. Standby Supply;- The load is alternatively connected to DG set of 82.5/125 KVA**

**2. PSPCL account No; U22 GC 220003KJ**

**3. Connected load;- 25.00 KW.**

**4. Location;- COLLEGE HOSTEL BLOCK.**

### **(B) Distribution**

**The energy is connected and distributed to different loads through**

**different sub distribution boards at all levels of the building by suitable and correct**

**Sizes of wire/ cables. Power factor is well maintained and is in specified limits**

### **(C) Safety**

**Satisfactory safety measures are being adopted by the consumer. All appliances, lighting fixture/ceiling/ exhaust fans are of BIS ratings and are in proper serviceable and working conditions. All light fixture are of LED type providing power factor close to unity with adequate lumens output.**

**All switch sockets are adequately protected from direct contact to live parts of switch boards**

**Earthing stations/plts are also provided and are found to be within permissible values**



## TUBEWELL MOTOR

### (A) Basic

1. Source of Energy ; PSPCL through KWH meter No. 058073 .
- 1 A. Standby Supply;- The load is alternatively connected to DG set of 82.5/125 KVA
2. PSPCL account No; U22 SP310013Y-C
3. Connected load;- 11.39 KW.
4. Location;- COLLEGE TUBEWELL MOTOR.

### (B) Distribution

The energy is connected and distributed to different loads through different sub distribution boards at all levels of the building by suitable and correct Sizes of wire/ cables. Power factor is well maintained and is in specified limits

### (C) Safety

Satisfactory safety measures are being adopted by the consumer. All appliances, lighting fixture/ceiling/ exhaust fans are of BIS ratings and are in proper serviceable and working conditions. All light fixture are of LED type providing power factor close to unity with adequate lumens output.

All switch sockets and motor starter are adequately protected from direct contact to live parts of switch boards.

Earthing stations/pits are also provided and are found to be within permissible values

**We harness solar energy on campus to promote sustainability  
and reduce our environmental impact."**





"We use LED lighting, energy-efficient equipment, and perform our duties responsibly to conserve energy."







 **GPS Map Camera**



Sidhwan Khurd, Punjab, India  
Link Road Sidhwan Kallan, Sidhwan Khurd, Punjab 142024, India  
Lat 30.827588°  
Long 75.553544°  
14/11/23 11:48 AM GMT +05:30



 **GPS Map Camera**



Sidhwan Khurd, Punjab, India  
Link Road Sidhwan Kallan, Sidhwan Khurd, Punjab 142024, India  
Lat 30.827588°  
Long 75.553544°  
14/11/23 11:47 AM GMT +05:30



 **GPS Map Camera**



**Sidhwan Khurd, Punjab, India**  
Link Road Sidhwan Kallan, Sidhwan Khurd, Punjab 142024, India  
Lat 30.827588°  
Long 75.553544°  
14/11/23 11:49 AM GMT +05:30

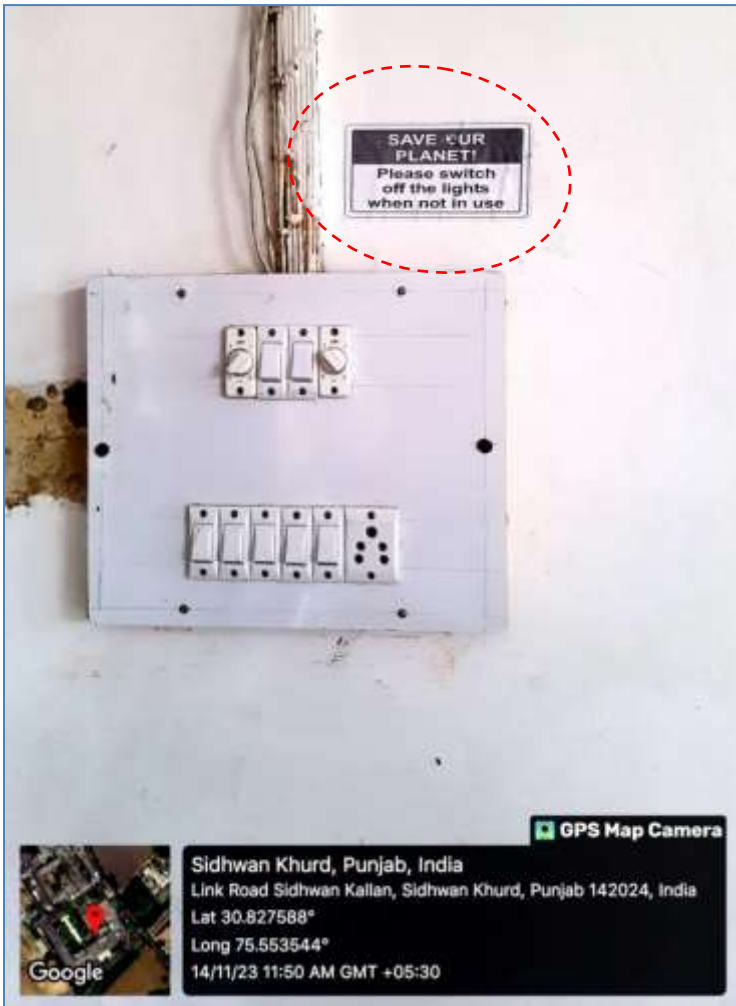



**SAVE  
ELECTRICITY**

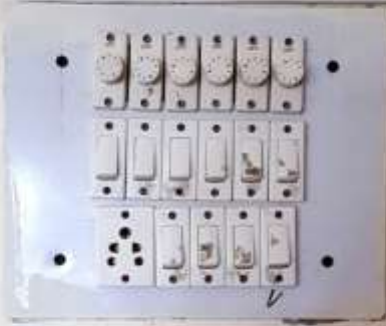

**Energy Saving  
Reminder**  
If you are the last to  
leave the room,  
please turn off  
the lights!



GPS Map Camera



Sidhwan Khurd, Punjab, India  
RHH3+2JG, Sidhwan Khurd Link Rd, Sidhwan Khurd, Punjab 142024, India  
Lat 30.8273893°  
Long 75.553803°  
14/11/23 11:39 AM GMT +05:30

Google

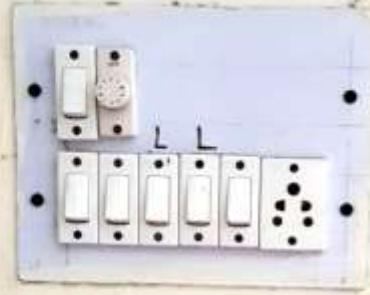

**SAVE OUR  
PLANET!**  
Please switch  
off the lights  
when not in use

GPS Map Camera



Sidhwan Khurd, Punjab, India  
RHH3+2JG, Sidhwan Khurd Link Rd, Sidhwan Khurd, Punjab 142024, India  
Lat 30.827347°  
Long 75.55378°  
14/11/23 11:40 AM GMT +05:30

Google

LED BILLS

Bill/Cash

(M) 98157-25000

# National Electric Store

Authorised Dealer :-  
Motor Rewinding, House Wiring, Electric & Electronic Material

Raikot Road, JAGRAON. (Ludhiana)

me. <sup>82</sup> P. Riasat Khanna college for women shekh  
Dated 25/7/23

Y.	Full Description of Goods	QNTY.	RATE	AMOUNT	
				Rs.	P.
	Tube Rod	10 ft	60/-	600	
	STARTER	10 ft	15/-	150	
	CAPACIT	20 ft	35/-	700	
	2 for 2000/- 2 for 1000/-			1800	
	Tube rods, starters and capacitors of fans for college campus.		32		
	3250				
	2700				
	5950				
	June 2023				
	<b>TOTAL</b>			3250	

**PAID**

Jasdeep  
Bursar  
Khalsa College for Women  
Sidhwar Khurd (Ludhiana)

Principal  
Khalsa College for Women  
Sidhwar Khurd (Ludhiana)

O.E.

Three thousand  
two hundred fifty  
only

For National Electric Store

Authorised Sign

Bill/Cash

(M) 98157-25000

# National Electric Store

Authorised Dealer :-

Motor Rewinding, House Wiring, Electric & Electronic Material

Raikot Road, JAGRAON. (Ludhiana)

66

Dated 29/9/2023

me Principal Khalsa College for women Sidhwan Khurd

Y.	Full Description of Goods	QNTY.	RATE	AMOUNT	
				Rs.	P.
	Pvc Batta	5ft	23/-		115/-
	1mm wu	10m	18/-		180/-
	Pvc gutter	2ft	40/-		80/-
	swls	1ft	25/-		25/-
	gan'ba	1ft	30/-		30/-
	Tube set	10ft	290/-		2900/-
	Principal office fitting + 10 LED Tube set				
	(B) Three thousand of Three hundred thirty only				
			<b>TOTAL</b>		3330 -

**PAID**

*Jinder Paul*  
Bursar  
Khalsa College for women  
Sidhwan Khurd (Ludhiana)

*[Signature]*  
Principal  
Khalsa College for women  
Sidhwan Khurd (Ludhiana)

& O.E.

*Gulab Singh*  
*[Signature]*  
3/10/23

For National Electric Store

Authorised S<sup>t</sup>



Bill/Cash

(M) 98157-25000

# National Electric Store

Authorised Dealer :-  
Motor Rewinding, House Wiring, Electric & Electronic Material

Raikot Road, JAGRAON. (Ludhiana)

Dated 30/9/23..

67  
Principal Bursar college for women side by

Full Description of Goods	QNTY.	RATE	AMOUNT	
			Rs.	P.
1mm two core wire	1000	2450/-	2450	-
Pvc gutter size	260	40/-	80	-
Switch	20	25/-	50	-
Socket	10	35/-	350	-
gang box	10	30/-	300	-
AC Dr.	20	360/-	7200	-
2.5 mm wire	1500	30/-	4500	-
Clamp	300	40/-	1200	-
<b>PAID</b>				
(1) A.C. electrical supply				
(2) Supply for LED tubelight in bookstore				
<b>TOTAL</b>			<b>3935-</b>	

(Rs) Three thousand nine hundred thirty five only

& O.E. *[Signatures]*

Bursar  
Khalsa College for women  
Sidhwan Khurd (Ludhiana)

For National Electric Store  
*[Signature]*  
Authorised Sign

Bill/Cash

(M) 98157-25000

# National Electric Store

Authorised Dealer :-

Motor Rewinding, House Wiring, Electric & Electronic Material

Raikot Road, JAGRAON. (Ludhiana)

68

LABOUR

Dated. 2/10/23

Principal Khalsa colony for women side Burear

Full Description of Goods	QNTY.	RATE	AMOUNT	
			Rs.	P.
Print. office furn + LED			1000	
A.C. FITTING	2	500	1000	
WIRE			1000	
<p>Labour</p> <p>(1) Principal office</p> <p>(2) Gurm Nanak Bhawan A.C. FITTING</p> <p>(3) 2 LED Tubset in Gurm Nanak Bhawan</p>			<p>PAID</p> <p>Principal Burear Khalsa College for women Sidhwan Khurd (Ludhiana)</p>	
<b>TOTAL</b>			3000/-	

(By) These three thousand only

O.E. Nandhla, G. Arora, Suresh, J. Singh

For National Electric Store  
Authorized Sign.



# Annual Staff Duty

## ports Committee

- Dr Paramdeep Singh
- Dr. Jasdeep Kaur
- Mr Ashwani Jain
- Ms Bhagwant Kaur

## 74. Student Aid Fund/Scholarship/ Fee Concession Committee

- Dr. Navdip Kaur (Convener)
- Dr. Gagandeep Dharni
- Prof. Inderjit Kaur
- Prof. Harwinder Kaur
- Mrs. Baldev Kaur Mann

## 75. Switching off Fans, Bulbs & Complete Locking

- Mrs. Amandeep Kaur- Main & PG Library
- Mr. Katar Singh- First Floor All Over
- Smt. Kuldeep Kaur- Ground Floor All Over
- Mrs Ramma Makkar – over all checking

## 76. Transport Committee

- S. Gurbakhshish Singh, Bus Supervisor
- S. Gagandeep Aulakh (Co-Convener)
- Mr Ashwani Jain- All bills related to Transport
- Mrs Harwinder Kaur

## 77. Teacher Induction Programme

- Dr. Navdip Kaur
- Dr Gagandeep Dharni

## 78. Time Table Committee

- Dr. Jasdeep Kaur
- Ms Rajni
- Mrs Ramanpreet Kaur

## 79. UGC and National Council for Teacher Education (NCTE) Committee

- Mr Puneet Wadhwa
- Dr. Parmjit Kaur
- Mrs. Baldev Kaur Mann (Off. Supdt.)
- Mr. Sanjay Kumar (Clerk)

## 80. Weekly Assembly/ Staff/ Students

### Attendance and Address by Teachers

- Dr Gagandeep Dharni (Convener)
- Mrs Karamdeep Kaur (Co-Convener)
- All announcements schedule of present
- Mrs Bhagwant Kaur
- Dr. Geetanjali Arora (Prayer, Harmonium)
- Mrs Jaspreet Kaur- Projector Setting
- Mrs Harmanpreet Kaur
- Mrs. Rama Makkar - Staff Attendance
- S. Jagraj Singh - Mike Setting

## 81. Website Updation

- Mr Puneet Wadhwa
- Mrs Ramanpreet Kaur

## 82. Youtube Channel & Facebook page of college -coordinator

- Mrs Jaspreet Kaur

Note: All the Staff Members are required to note all the duties and put signatures in front of his/her name. It is also informed you that all the staff members will perform his/her duty with full responsibility and in time. Undersigned will not remind any duty to anyone.

Principal  
Khalsa College for Women,  
Sidhwan Khurd (Ludhiana)



By embracing alternatives and promoting eco-friendly practices, we are taking a significant step towards preserving the environment for generations to come.





# Installation of Tree Nest

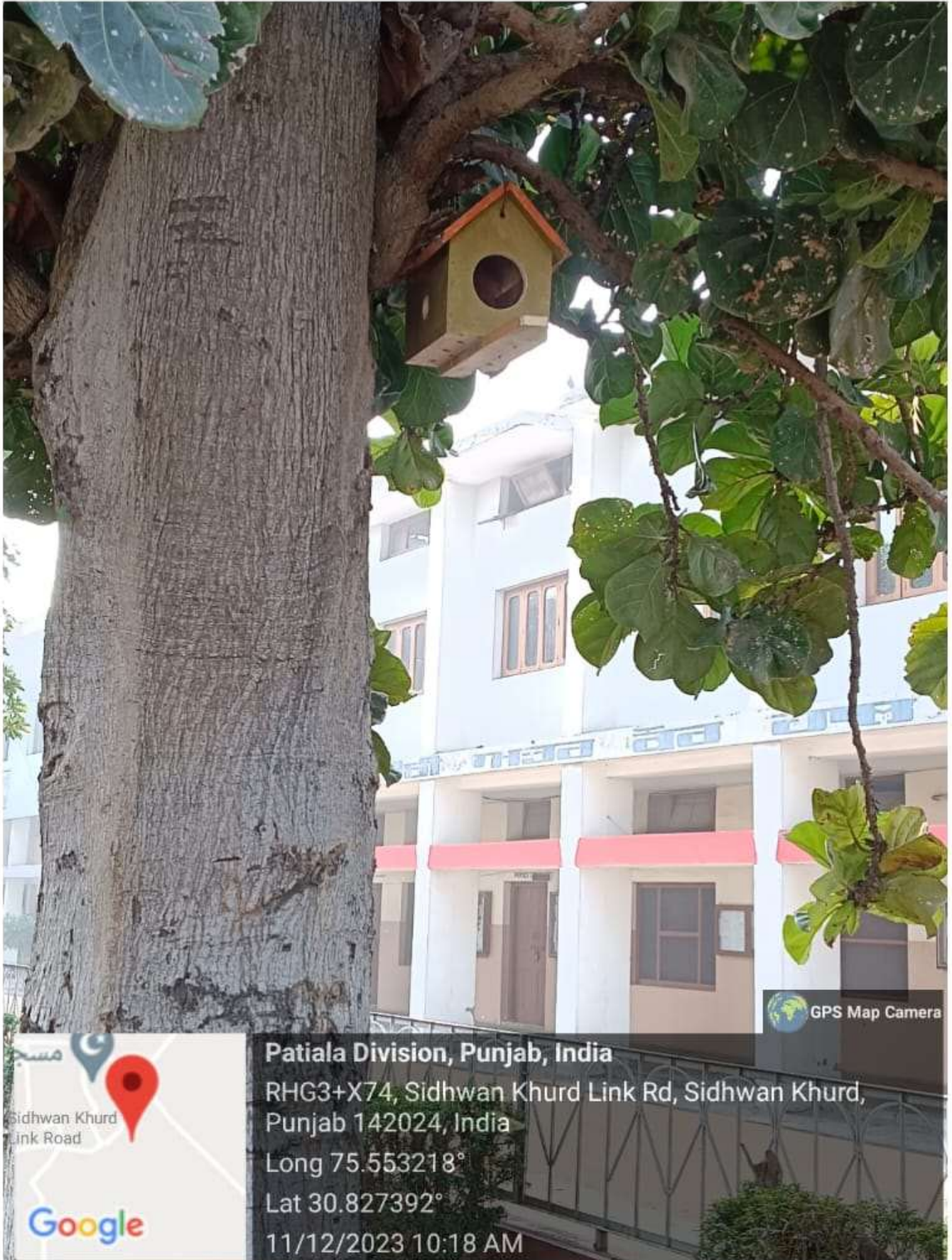

GPS Map Camera



Patiala Division, Punjab, India

RHG3+X74, Sidhwan Khurd Link Rd, Sidhwan Khurd,  
Punjab 142024, India

Long 75.553218°

Lat 30.827392°

11/12/2023 10:18 AM

# Curriculum related to Environment

## Environment, Road Safety Education, Violence against Women/Children and Drug Abuse SEMESTER II

### Instructions :

- The total duration of the whole paper (consisting of four parts) shall be of 2 hours carrying 100 marks in whole, divided into the ratio of 40:20:20:20
- The teaching hours for the Environment portion of this paper, would be 20 and of Road Safety, Violence against Women/Children and Drug Abuse shall be 10 hours each.

### Part - I (Environment)

**Note:** *The syllabus has 15 topics to be covered in 20 hour lectures in total, with 2 lectures in each topic from 2 to 11 and one each for the topics 1 and 12 to 15.*

1. **Environment Concept :**  
Introduction, concept of biosphere—lithosphere, hydrosphere, atmosphere; Natural resources—their need and types; principles and scope of Ecology; concepts of ecosystem, population, community, biotic interactions, biomes, ecological succession.
2. **Atmosphere :**  
Parts of atmosphere, components of air; pollution, pollutants, their sources, permissible limits, risks and possible control measures.
3. **Hydrosphere :**  
Types of aquatic systems. Major sources (including ground water) and uses of water, problems of the hydrosphere, fresh water shortage; pollution and pollutants of water, permissible limits, risks and possible control measures.
4. **Lithosphere :**  
Earth crust, Soil—a life support system, its texture, types, components, pollution and pollutants, reasons of soil erosion and possible control measures.
5. **Forests :**  
Concept of forests and plantations, types of vegetation and forests, factors governing vegetation, role of trees and forests in environment, various forestry programmes of the Govt. of India, Urban Forests, Chipko Andolan.
6. **Conservation of Environment :**  
The concepts of conservation and sustainable development, why to conserve, aims and objectives of conservation, policies of conservation; conservation of life support systems—soil, water, air, wildlife, forests.
7. **Management of Solid Waste :**  
Merits and demerits of different ways of solid waste management—open dumping, landfill, incineration, resource reduction, recycling and reuse, vermicomposting and vermiculture, organic farming.



8. **Indoor Environment :**  
Pollutants and contaminants of the in-house environment; problems of the environment linked to urban and rural lifestyles; possible adulterants of the food; uses and harms of plastics and polythene; hazardous chemicals, solvents and cosmetics.
9. **Global Environmental Issues :**  
Global concern, creation of UNEP; Conventions on climate change, Convention on biodiversity; Stratospheric ozone depletion, dangers associated and possible solutions.
10. **Indian Laws on Environment :**  
Indian laws pertaining to Environmental protection : Environment (Protection) Act, 1986; General information about Laws relating to control of air, water and noise pollution. What to do to seek redressal.
11. **Biodiversity :**  
What is biodiversity, levels and types of biodiversity, importance of biodiversity, causes of its loss, how to check its loss; Hotspot zones of the world and India, Biodiversity Act, 2002.
12. **Noise and Microbial Pollution :**  
Pollution due to noise and microbes and their effects.
13. **Human Population and Environment :**  
Population growth and family welfare programme, Human Health, HIV/AIDS, Human rights.
14. **Social Issues :**  
Environmental Ethics : Issues and possible solutions, problems related to lifestyle, sustainable development; Consumerisms and waste generation.
15. **Local Environmental Issues :**  
Environmental problems in rural and urban areas, Problem of Congress grass & other weeds, problems arising from the use of pesticides and weedicides, smoking etc.

**Practicals:**

Depending on the available facility in the college, a visit to Vermicomposting units or any other such non-polluting eco-friendly site or planting/caring of vegetation/trees could be taken.

**Examination Pattern :**

A qualifying paper of 40 marks comprising of 40 multiple choice questions (with one correct and three incorrect alternatives and no deduction for wrong answer or unattempted question), and of 1 hour duration.

The students have to obtain 33% marks to qualify the paper. The marks are not added/included in the final mark sheet.

# Plantation Bills

M.: 98884-83662	<b>BILL/CASH</b>	M. 79863-64564			
<h2 style="margin: 0;">NEW DURGA NURSERY</h2>					
In Our Nursery Every Type of Fruits, Flowers are Available in Minimum Rates.					
Malerkotla Road, Near Village Rania, J.K. Resorts, Ludhiana.					
To M/s. <u>Principal KCW Sidhwan</u> <u>Khurd, Ludhiana.</u>	No. <b>245</b>	Dated. <u>04/02/24</u>			
S No.	Qty.	PARTICULARS	RATE	AMOUNT	
1	5	Grass pot	50	250	Rs.
2	5	Limbo grass	50	250	P.
3	5	Synonium	50	250	
4					
5					
6					
7					
8					
9					
10					
11					
12					
13					
14					
15					
16					
<b>PAID</b>					
for Guests International one day Punjabi Dept Seminar - 06/02/2024					
Bursar Khalsa College for women Sidhwan Khurd (Ludhiana)					
Principal					
Total				750	Rs.
Rs. in Words <u>Seven hundred fifty only</u>					
Subject to Ludhiana Jurisdiction. Goods once sold are not to be returnable					
E & O. E.					
For NEW DURGA NURSERY					



GSTIN : 03AAKCC9372Q1ZY

**TAX INVOICE**  
ORIGINAL FOR RECIPIENT

Ph :  
(M) :

# COSMOS RECYCLING PRIVATE LIMITED

SCO 86, NEW GRAIN MARKET, GILL ROAD,  
LUDHIANA LUDHIANA

E-mail :

Details of Receiver (Billed To):

**KHALSA COLLEGE FOR WOMEN**  
SIDHWAN KHURD, 142024  
DISTT-LUDHIANA

State: Punjab  
GSTIN:

State Code : 03  
PAN :

INVOICE No.  
**CRPL2**

Date:  
**27.02.2024**

Transport :

GR.No. :

Date : . . .

Details of Consignee (Shipped To):

**KHALSA COLLEGE FOR WOMEN**  
SIDHWAN KHURD, 142024  
DISTT-LUDHIANA



State : Punjab  
GSTIN :

State Code : 03  
PAN :

VEHICLE NO

Bank Details:

**ICICI BANK**  
A/C NO:393905500084  
IFSC CODE:ICIC0003939  
HAMBRAAN,LUDHIANA

SR. No.	Description of Goods	HSN/ SAC	Pcs	Qty	Unit	Rate	Dis.	GST Rate	Amount
1	SERVICE AGREEMENT CHARGES	999432		1		5000.00		18.00%	5000.00
<b>PAID</b>									
 									
Bursar Khalsa College for women Sidhwan Khurd (Ludhiana)									
Principal Khalsa College for women Sidhwan Khurd (Ludhiana)									
<i>(Five thousand Nine Hundred Only)</i>									
<b>Totals :</b>									5000.00

Taxable	Rate	IGST	Rate	CGST	Rate	SGST	TOTAL		
	0.00%		0.00%	0.00	0.00%	0.00	0.00		
5000.00	0.00%		9.00%	450.00	9.00%	450.00	900.00	<b>Sub-Total:</b>	
	0.00%		0.00%	0.00	0.00%	0.00	0.00	<b>Taxable Value:</b>	
	0.00%		0.00%	0.00	0.00%	0.00	0.00	<b>CGST: 9.00%</b>	
	0.00%		0.00%	0.00	0.00%	0.00	0.00	<b>SGST: 9.00%</b>	
5000.00			450.00		450.00		900.00	<b>Round Off:</b>	
								<b>BILL AMOUNT</b>	<b>5900.00</b>

Amt. in Words: Rupees Five Thousand Nine Hundred Only

**Terms & Conditions:**

- No replacement/exchange/refund against this Invoice.
- Our responsibility ceases when goods leaves our godown.
- Interest @24% p.a. will be charged on delayed payments.
- All Disputes are subject to LUDHIANA Jurisdiction.

E.&.O.E.

For COSMOS RECYCLING PRIVATE LIMITED

Mohit Jindal

Auth. Signatory





# KHALSA COLLEGE FOR WOMEN

(Reaccredited Grade B++ by NAAC)

SIDHWAN KHURD- 142024

DISTT-LUDHIANA(PB.)

Ref No... *S. F. 102/24*

Dated... *22.02.24*

To

The Manager  
Punjab National Bank  
Sidhwan Khurd  
Ludhiana.

Subject: Payment through RTGS to Cosmos Recycling Private Limited on account of MOU for e-waste management  
Sir,

You are requested to make the payment through RTGS vide cheque No *218259* dated *22.02.24* Rs. 5900/- (Rupees Five thousand Nine hundred only) from our Account No. 09802010000030. The detail of the Beneficiary is as under:-

Beneficiary's Name	: Cosmos Recycling Private Limited
Account Number	: 393905500084
Reconfirm Account Number	: 393905500084
Bank Name	: ICICI BANK
IFSC Code	: ICIC0003939
Branch Address	: Hambran
Amount	: 5900/-
Mobile No.	7814368798

Regards, -

Sincerely,



*22/2/24*

*Principal*

Principal  
Khalsa College for women  
Sidhwan Khurd, Ludhiana

*[Signature]*

ਖਾਲਸਾ ਕਾਲਜ ਫਾਰ ਵਿਮੈਨ ਸਿਧਵਾਂ ਖੁਰਦ (ਲੁਧਿਆਣਾ)

*Amalgamated Fund*

ਬਿੱਲ ਨੰਬਰ .....

ਮਿਤੀ 19.04.23

ਕਿਸ ਨੂੰ ਦਿੱਤੇ	ਕਿਸ ਮੌਤਵ ਲਈ	ਕੁੱਲ ਜੋੜ	ਰੁਪੇ	ਪੈ
<i>Salsg Ram Mali</i>	<i>Paid in cash on account of purchase of refreshment material and plants for Eastern zone lecture by JAC</i>	<i>Four to meet twenty</i>	<i>420</i>	
	ਕਿਸ ਤੋਂ ਲਏ - <i>only</i>			
	ਕਿਸ ਮੌਤਵ ਲਈ -			
	<i>Bill 100</i>			
	<i>320</i>			
	<i>420</i>			
	ਕੁੱਲ ਜੋੜ			

ਲੇਖਾਕਾਰ ਖਜਾਨਚੀ ਪ੍ਰਿੰਸੀਪਲ

ਪੰਜਾਬ ਸਾਹਿਤ ਕਲ ਕਮੇਟੀ  
*Salsg Ram Mali*  
 ਵਿਸ ਮੌਤਵ ਲਈ *Refreshment and Plants*  
 ਵਾਲ ਕਮੇਟੀ

ਕਮੇਟੀ ਵਾਲ ਕਮੇਟੀ  
*420/-*  
 ਪ੍ਰਭਾਕਰ ਦੇ ਦਸਤਖਤ



*Handed over*  
 Burear Principal  
 Khalsa College for women  
 Sidhwan Khurd (Ludhiana)

Bill/Cash

Mob: 94176-62038



# ਰਾਮ ਰਾਜ ਮੌਰੀਆ ਨਰਸਰੀ

ਸਾਹਮਣੇ HP ਪੈਟਰੋਲ ਪੰਪ, ਨੇੜੇ ਦਿਓਲ ਹਸਪਤਾਲ, ਮੁੱਲਾਂਪੁਰ ਦਾਖਾ (ਲੁਧਿਆਣਾ)

ਇੱਥੇ ਹਰ ਤਰ੍ਹਾਂ ਦੇ ਫੁੱਲਾਂ, ਫਲਾਂ, ਇੰਨਡੋਰ ਅਤੇ ਆਊਟਡੋਰ ਬੂਟੇ ਅਤੇ ਮਿੱਟੀ ਦੇ ਗਮਲੇ ਮਿਲਦੇ ਹਨ। ਮਿੱਟੀ ਦੇ ਭਾਂਡੇ ਮਿਲਦੇ ਹਨ।

To M/s. <u>ਖਾਲਸਾ ਕਾਲਜ</u>	No. <b>778</b>
<u>ਸਿੱਧਵਾ ਖੁਰਦ</u>	Dated <u>20/4/23</u>

Qty.	PARTICULARS	Rate	Amount Rs.	P.
8	Krofan Plant (5" pot)	70	560	
<p>For welcoming the resource persons on 7 Days FDP April 21-29, 2023</p> <p>Saligram</p>				
TOTAL			560/-	

*Jasdeep Singh*  
Bursar  
Khalsa College for women  
Sithwan Khurd (Ludhiana)

*Principal*  
Principal  
Khalsa College for women  
Sithwan Khurd (Ludhiana)

**Ram Raj Maurya Nursery**  
Opp. H.P. Petrol Pump, Mullampur  
E. & O.E.

*21/4/23* *21/4/23* *Signature*



71-89788

ॐ BILL/CASH ॐ

M. 62845-80698

# Mathur Nursery

Ferozepur Road, Sarabha Nagar,  
Opp. PAU Gate No. 2, Ludhiana

To M/s. Khalsa College for Women  
Sidhwan Khurd (Ldh)

No. **205**

Dated 26.3.2024

S No.	Qty.	PARTICULARS	RATE	AMOUNT	
				Rs.	P.
1	4	सप्लिंग्स	50	200	
2					
3					
4					
5					
6					
7					
8					
9					
10		4 Saplings for Cereals			
11		Counselling Lecture			
12		on 27/03/24			
13		at Gurus Nanak Ashram			
14					
15					
16				200	
Rs. Two hundred only			Total		

**PAID**

Bursar  
Princhen  
Khalsa College for women  
Sidhwan Khurd (Ludhiana)

*Ashwan Jain*

Rs. in Words

Subject to Ludhiana Jurisdiction.  
Goods once sold are not to be returnable

E. & O. E.

For Mathur Nursery

Signature

# Annual Staff Duty

43. Instagram and Tweeter Account
- Ms Avneet Kaur
  - Ms Harpreet Kaur (Comp)
44. Incharge College Equipments
- Mrs. Baldev Kaur Mann- Administration Office
  - Mr Puneet Wadhwa- Library Equipments & Laptops, Principal Office, LCD, TV Sets, Computer Labs Equipments (4-6)
  - Mrs Ramanpreet Kaur- Smart Boards
  - Mrs Jaspreet Kaur- Handy Camera, CCTV Cameras, Lab Equipments (1-3)
  - S. Gagandeep Aulakh & S. Jagraj Singh- (Air Conditioners, Water Purifiers, Generator, All Electrical & Water Equipments, Water Dispensers, Water Coolers, Tube Lights, Bulbs, Sound System, Submersible Motor and Water Taps)
  - S. Jagraj Singh- To help the above Incharges.
45. Landscaping & Maintenance of College Campus
- Prof. Ashish Kumar
  - Dr Paramdeep Singh
  - Sh. Salig Ram
  - Sh. Rajnish Kumar
46. LMS
- Mr Puneet Wadhwa
  - Ms Harpreet Kaur (Comp)
47. Leave to Students Committee
- All Mentors
  - Mrs Baldev Kaur Mann
  - S. Jagraj Singh - Record keeping of leaves of students
48. Library/Book Bank Committee
- Dr. Mahipal Dutt (Convener)
  - Mrs Harwinder Kaur
  - Dr. Amandeep Kaur
49. Prof. Ashish Kumar
50. NCC
- Dr Balwinder Kaur (Incharge)
  - Mrs. Baldev Kaur Mann, Off. Supdt.
  - S. Jagraj Singh
51. New Courses Committee (UGC & PU Chd)
- Mr Puneet Wadhwa, Convener
  - Mrs Jaspreet Kaur
  - Mrs Ramanpreet Kaur
  - Dr. Parmjit Kaur
  - Mrs. Baldev Kaur Mann
52. NSS
- Ms Inderjit Kaur- 1<sup>st</sup> Unit
  - Mr Ashish Kumar- 2<sup>nd</sup> Unit
53. Parent Teacher Association
- Dr. Gagandeep Dharni
  - Dr. Balwinder Kaur
  - Ms Nidhi
54. Placement cell
- Mr. Puneet Wadhwa
  - Dr Jasdeep Kaur
  - Mr Ashwani Jain
55. PAR Committee
- Mr Puneet Wadhwa
  - Dr. Parmjit Kaur
  - Ms. Bhagwant Kaur
  - Mr. Sanjay Kumar (Clerk)
56. Photography and Videography Committee
- Mrs Ramanpreet Kaur (Computer)
  - Mrs Harwinder Kaur (Commerce)
  - Dr. Amandeep Kaur (Science)
  - Mr Ashish Kumar
  - Dr. Mahipal Dutt for Photographs record in Library.
57. Picnic and Tours Committee
- Prof. Inderjit Kaur (Convener)
  - Dr. Mahipal Dutt
  - Dr Paramdeep Singh

## Activities



## Khalsa College for Women Sidhwan Khurd observes “ Swachhta hi Sewa” Cleanliness Drive

Under the able guidance of Dr. Amandeep Kaur, Principal (Addl.Charge) and as per the directions of Higher Education Department, Punjab Government, the NSS Units, NCC Unit and Cleanliness Committee of Khalsa College for Women, Sidhwan Khurd collectively undertook Swachhta Drive under “Swachhta hi Sewa” programme from September 15 to October 2,2023. As a part of this event various activities were conducted. Marathon was held on 16.9.2023. Lecture on ‘Say no to Plastic’ was organized on 20.9.2023 and oath to observe cleanliness was taken on 24.9.2023. Lecture on ‘Waste Management’ was held on 26.9.2023. Awareness Rally to spread the message of cleanliness was taken out at Sidhwan Khurd village on 29.9.2023. The programme reached its culmination on 2.10.2023 with the celebration of ‘Swachhta Diwas’ as ‘Mera Campus, Swachh Campus’ by organizing lecture, elocution and poster making.

Dr. Navdip Kaur, congratulated the students and NSS Programme Officers Dr. Inderjit Kaur and Prof. Ashish Kumar for organizing this drive and contributing to national service. She inspired everyone to keep their surroundings neat and clean.





# 'ਸਵੱਛਤਾ ਹੀ ਸੇਵਾ' ਅਭਿਆਨ ਤਹਿਤ ਸਮਾਗਮ ਆਯੋਜਿਤ

ਜਗਰਾਓ, 2 ਅਕਤੂਬਰ (ਮਾਲਵਾ) ਖਾਲਸਾ ਕਾਲਜ ਡਾਰ ਵਿਮਨ, ਸਿੱਧਵਾਂ ਖੁਰਦ ਵਿਖੇ ਡਾਇਰੈਕਟਰ ਉਦੇਗੀ ਸਿੱਖਿਆ ਵਿਭਾਗ ਦੇ ਦਿਸ਼ਾ-ਨਿਰਦੇਸ਼ਾਂ ਤਹਿਤ "ਸਵੱਛਤਾ ਹੀ ਸੇਵਾ" ਅਭਿਆਨ ਚਲਾਇਆ ਗਿਆ। ਸੰਸਥਾ ਦੇ ਪਿੰਸੀਪਲ ਡਾ. ਅਮਨਦੀਪ ਕੌਰ (ਐਡੀਸ਼ਨਲ ਚਾਰਜ) ਦੀ ਯੋਗ ਅਗਵਾਈ



ਗਤੀਵਿਧੀਆਂ 'ਚ ਭਾਗ ਲੈਣ ਵਾਲੇ ਵਿਦਿਆਰਥੀਆਂ ਨਾਲ ਸਟਾਫ਼। (ਮਾਲਵਾ)

ਪਲਾਸਟਿਕ ਵਿਸ਼ੇ ਤੇ ਆਪਣੇ ਵਿਚਾਰ ਸਾਂਝੇ ਕੀਤੇ। ਇਸ ਮੌਕੇ ਇਤਿਹਾਸ ਵਿਭਾਗ ਦੇ ਮੁਖੀ ਡਾ. ਨਵਦੀਪ ਕੌਰ ਨੇ ਵਿਦਿਆਰਥਣਾਂ ਨੂੰ ਮੁਖਾਤਿਬ ਹੁੰਦਿਆਂ ਕਾਲਜ ਕੈਂਪਸ ਦੀ ਸਫ਼ਾਈ, ਪਰਿਵਾਰ ਅਤੇ ਨਿੱਜੀ ਪੱਧਰ ਤੇ ਸਵੱਛ ਹੋਣ ਦੀ ਪ੍ਰੇਰਨਾ ਦਿੱਤੀ। ਉਹਨਾਂ ਗਾਂਧੀ ਜੀ ਦੇ ਦਰਸਾਏ ਪੰਥ ਨੂੰ ਨੌਜਵਾਨ ਵਰਗ ਦੁਆਰਾ ਉਸਾਰੂ ਲੀਹਾਂ 'ਤੇ

ਅਧੀਨ ਐੱਨ ਐੱਸ ਐੱਸ. ਅਤੇ ਐੱਨ ਸੀ ਸੀ. ਯੂਨਿਟਾਂ ਵੱਲੋਂ ਵਿਭੰਨ ਗਤੀਵਿਧੀਆਂ ਆਯੋਜਿਤ ਕੀਤੀਆਂ, ਜਿਨ੍ਹਾਂ ਵਿਚ ਕਾਲਜ ਕੈਂਪਸ ਦੀ ਸਫ਼ਾਈ, ਸਵੱਛਤਾ ਲਈ ਜਾਗਰੂਕਤਾ ਹਿਤ ਸਿੱਧਵਾਂ ਖੁਰਦ ਪਿੰਡ ਵਿਚ ਜਾਗਰੂਕਤਾ ਰੈਲੀ, ਮੈਰਾਥਨ, ਪਲਾਸਟਿਕ ਦੀ ਵਰਤੋਂ ਬੰਦ ਕਰਨ ਲਈ ਲੈਕਚਰ ਅਤੇ ਪੋਸਟਰ ਮੈਕਿੰਗ ਮੁਕਾਬਲੇ ਆਯੋਜਿਤ ਕੀਤੇ ਗਏ।

2 ਅਕਤੂਬਰ ਨੂੰ ਰਾਸ਼ਟਰ ਪਿਤਾ ਮਹਾਤਮਾ ਗਾਂਧੀ ਜੀ ਦੇ ਜਨਮ ਦਿਵਸ ਮੌਕੇ ਉਲੀਕ ਪ੍ਰੋਗਰਾਮ ਵਿਚ ਵਿਦਿਆਰਥਣਾਂ ਨੇ ਗਾਂਧੀ ਜੀ ਦੇ ਦਰਸਾਏ ਮਾਰਗ ਦਰਸ਼ਨ, ਸਫ਼ਾਈ ਪ੍ਰਤੀ ਚੇਤਨਾ ਅਤੇ ਸੇ-ਨੋ-ਟੂ

ਲੈ ਕੇ ਜਾਣ ਲਈ ਉਤਸ਼ਾਹਿਤ ਕੀਤਾ।

ਡਾ. ਗਗਨਦੀਪ ਧਾਰਨੀ ਨੇ ਵੀ ਪਲਾਸਟਿਕ ਦੀ ਵਰਤੋਂ ਬੰਦ ਕਰਨ ਤੇ ਕੈਂਪਸ ਦੀ ਸਫ਼ਾਈ ਨੂੰ ਤਰਜੀਹ ਦਿੱਤੀ। ਐਨ. ਐਸ. ਐਸ ਦੇ ਪ੍ਰੋਗਰਾਮ ਅਫ਼ਸਰ ਡਾ. ਇੰਦਰਜੀਤ ਕੌਰ ਅਤੇ ਸ਼੍ਰੀ ਆਬੀਸ਼ ਕੁਮਾਰ ਨੇ ਵੀ ਪ੍ਰਭਾਵਸ਼ਾਲੀ ਸ਼ਬਦਾਂ ਸਹਿਤ ਵਲੰਟੀਅਰਾਂ ਨੂੰ ਸਫ਼ਾਈ ਬਰਕਰਾਰ ਰੱਖਣ ਲਈ ਪ੍ਰੇਰਿਤ ਕੀਤਾ। ਸੰਸਥਾ ਦੇ ਸਟਾਫ਼ ਮੈਂਬਰ ਅਤੇ ਵਿਦਿਆਰਥਣਾਂ ਦੀ ਹਾਜ਼ਰੀ ਨਾਲ 'ਸਵੱਛਤਾ ਅਭਿਆਨ' ਦਾ ਇਹ ਸਮਾਗਮ ਸਫਲਤਾਪੂਰਵਕ ਸੰਪੰਨ ਹੋਇਆ।



**KHALSA COLLEGE FOR WOMEN**  
**(Reaccredited Grade B++ by NAAC)**

SIDHWAN KHURD-142024

DISTT-LUDHIANA (PB.)

Dated... 03.10.2023

Ref No... NSS/694

To

The Programme Coordinator,  
National Service Scheme (NSS)  
Panjab University  
Chandigarh

Subject: Activities conducted under the campaign "SWACHHATA HI SEWA- SWACHHATA ABHIYAN"

Sir,

Reference to your email received on 15.09.2023.

As per the direction of Director of Youth Welfare, Punjab and NSS Coordinator, Panjab University Chandigarh the NSS Units of this college participated in 'SWACHHATA HI SEWA- SWACHHATA ABHIYAN' campaign. The following activities were conducted from 09.08.2023 to 15.08.2023 in which 200 Volunteers participated with full zeal and enthusiasm. 15.09.2023 to 02.10.2023

- 16.09.2023- Marathon by volunteers.
- 20.09.2023- lecture on 'Waste Management'.
- 24.09.2023- Cleanliness was done in the college campus and pledge was taken by volunteers
- 26.09.2023- Lecture on 'Say No to Plastic'
- 29.09.2023- Rally in Sidhwan Khurd village.
- 01.10.2023- Cleanliness drive in the campus.
- 02.10.2023- Celebrated as Swachhata Diwas- Lecture on Sawachhata, Poster making and Elocution by volunteers were conducted.

Thanking you.

Yours faithfully,

Nand Lal Kaur  
Principal,  
Khalsa College for Women,  
Sidhwan Khurd (Ludhiana)

Programme Officers

3. Dr. Inderjit Kaur *Dr. Inderjit Kaur*

4. Mr. Ashish Kumar *Ashish Kumar*



## Seven Days NSS Camp Inaugrated at KCW, Sidhwan Khurd

Seven Days NSS Camp, commenced at Khalsa College for Women, Sidhwan Khurd (Ludhiana) on March 16, 2024. The theme of this camp is “Sawachh Bharat & Meri Maati Mera Desh”. The Camp was inaugurated by Principal Dr. Amandeep Kaur. College Shabad “De Shiva Varmohe” was recited to seek the blessings of the Almighty. NSS theme song was sung by NSS volunteers. Dr. Amandeep Kaur, Principal inspired the students to improve and protect the quality of natural environment and congratulated the volunteers for their enthusiastic participation in the camp. She also encouraged the volunteers to inculcate the habit of serving the society in their daily routine. After this the students were acquainted with the aims & objectives of the Camp. NSS Programme officer Dr. Inderit Kaur enlightened the volunteers on the significance of the theme adopted for the camp. Committees were constituted and students were assigned tasks to be completed during the camp. NSS Volunteers undertook cleanliness of the college campus and lawns. Volunteer Jyoti told about the importance of NSS.





# NSS (National Service Scheme)

22-March-2024

Date \_\_\_\_\_  
Page No. \_\_\_\_\_

S.No.	Name	Class	Roll No	Sign
1	Simranpreet Kaur	B.A III	710	Simranpreet
2	Manpreet Kaur	B.A III	718	Manpreet K.
3	Jyoti Kumari	B.A III	711	Jyoti Kumari
4	Jaspreet Kaur	B.A. B.Ed III	2304	Jaspreet
5	Pooja	B.A III	707	Pooja
6	Kashish	B.A   B.Ed III	2303	Kashish.
7	Sukhmandeep Kaur	BA (II)	419	Sukhman
8	Gagandeep Kaur	BA (II)	429	Gagandeep K.
9	Hardeep Kaur	B.A. I	40	Hardeep Kaur
10	Surinder Kaur	BA I	08	Surinder Kaur
11	Sarveen Kaur Bhullar	BA II	402	Sarveentan Bhull
12	Palminder Kaur	BA II	408	Palminder Kaur
13	Harpreet Kaur	B.A. I	12	Harpreet Kaur
14	Pungun	BA I	01	Pungun
15	Sumandeep Kaur	M.A I (Pbi)	2601	Suman
16	Jashanpreet Kaur	M.A I (Pbi)	2603	Jashan
17	Simranjeet Kaur	B.A II	409	Simranjeet K.
18	Ashdeep Kaur	II	404	Ashdeep K.
19	Kiranjeet K.	BA. Bed II	2252	Kiran
20	Hardeep Kaur	BA. Bed I	2208	Hardeep Kaur
21	Jyoti Kumari	BA III	719	Jyoti Kumari
	Muskaan Kaur	BA 2	401	Muskaan Kaur
	Sehraj	BA 2	411	Sehraj





■ ਖਾਲਸਾ ਕਾਲਜ ਫ਼ਾਰ ਵਿਮੈਨ ਸਿੱਧਵਾਂ ਖੁਰਦ ਵਿਖੇ ਸੱਤ ਰੋਜ਼ਾ ਐੱਨ.ਐੱਸ.ਐੱਸ. ਕੈਂਪ ਦਾ ਆਗਾਜ਼ ਕਰਨ ਸਮੇਂ ਵਿਦਿਆਰਥਣ ਨਾਲ ਪ੍ਰੋਗਰਾਮ ਅਫ਼ਸਰ ਡਾ. ਇੰਦਰਜੀਤ ਕੌਰ ਅਤੇ ਹੋਰ।  
ਤਸਵੀਰ: ਤੇਜਿੰਦਰ ਸਿੰਘ ਚੱਢਾ

## ਸਿੱਧਵਾਂ ਕਾਲਜ ਵਿਖੇ ਸੱਤ ਰੋਜ਼ਾ ਐੱਨ.ਐੱਸ.ਐੱਸ. ਕੈਂਪ ਦਾ ਆਗਾਜ਼

ਚੌਕੀਮਾਨ, 16 ਮਾਰਚ (ਤੇਜਿੰਦਰ ਸਿੰਘ ਚੱਢਾ)-ਖਾਲਸਾ ਕਾਲਜ ਫ਼ਾਰ ਵਿਮੈਨ ਸਿੱਧਵਾਂ ਖੁਰਦ ਦੇ ਪ੍ਰਿੰਸੀਪਲ ਡਾ. ਅਮਨਦੀਪ ਕੌਰ ਦੀ ਯੋਗ ਅਗਵਾਈ ਅਧੀਨ ਅਤੇ ਐੱਨ.ਐੱਸ.ਐੱਸ. ਪ੍ਰੋਗਰਾਮ ਅਫ਼ਸਰ ਦੇ ਸਹਿਯੋਗ ਨਾਲ ਸੱਤ ਰੋਜ਼ਾ ਐੱਨ.ਐੱਸ.ਐੱਸ. ਕੈਂਪ ਦਾ ਆਗਾਜ਼ ਕੀਤਾ ਗਿਆ। ਸਵੱਛ ਭਾਰਤ ਅਤੇ ਮੇਰੀ ਮਾਟੀ ਮੇਰਾ ਦੇਸ਼ ਵਿਸ਼ੇ ਦੇ ਤਹਿਤ ਆਯੋਜਿਤ ਇਸ ਕੈਂਪ ਦੀ ਸ਼ੁਰੂਆਤ ਪ੍ਰਮਾਤਮਾ ਦਾ ਓਟ ਆਸਰਾ ਲੈਂਦੇ ਹੋਏ ਕਾਲਜ ਸ਼ਬਦ ਨਾਲ ਹੋਈ। ਪ੍ਰਿੰਸੀਪਲ ਡਾ. ਅਮਨਦੀਪ ਕੌਰ ਨੇ ਵਿਦਿਆਰਥਣਾਂ ਨੂੰ ਵਾਤਾਵਰਨ ਦੀ ਸਾਂਭ-ਸੰਭਾਲ ਅਤੇ ਰਾਸ਼ਟਰ ਪ੍ਰਤੀ ਸੇਵਾ ਲਈ ਹਮੇਸ਼ਾਂ

ਤਿਆਰ-ਬਰ-ਤਿਆਰ ਰਹਿਣ ਦੀ ਪ੍ਰੇਰਨਾ ਦਿੱਤੀ। ਪ੍ਰੋਗਰਾਮ ਅਫ਼ਸਰ ਡਾ. ਇੰਦਰਜੀਤ ਕੌਰ ਨੇ ਐੱਨ.ਐੱਸ.ਐੱਸ. ਥੀਮ 'ਸਵੱਛ ਭਾਰਤ ਮੇਰੀ ਮਾਟੀ ਮੇਰਾ ਦੇਸ਼' 'ਤੇ ਆਪਣੇ ਵਿਚਾਰ ਪ੍ਰਗਟ ਕੀਤੇ ਅਤੇ ਵਲੰਟੀਅਰਾਂ ਨੂੰ ਸਮਾਜ ਪ੍ਰਤੀ ਸੇਵਾ ਭਾਵਨਾ ਲਈ ਉਤਸ਼ਾਹਿਤ ਕੀਤਾ। ਐੱਨ.ਐੱਸ.ਐੱਸ. ਵਲੰਟੀਅਰਾਂ ਨੇ ਐੱਨ.ਐੱਸ.ਐੱਸ. ਗੀਤ ਗਾਇਨ ਕੀਤਾ ਅਤੇ ਵਲੰਟੀਅਰ ਜੋਤੀ ਨੇ ਐੱਨ.ਐੱਸ.ਐੱਸ. ਦਾ ਵਿਦਿਆਰਥੀ ਜੀਵਨ ਵਿਚ ਮਹੱਤਵ ਵਿਸ਼ੇ 'ਤੇ ਵਿਚਾਰ ਸਾਂਝੇ ਕੀਤੇ। ਕੈਂਪ ਦੇ ਪਹਿਲੇ ਦਿਨ ਵਲੰਟੀਅਰਾਂ ਨੇ ਕਾਲਜ ਕੈਂਪਸ ਵਿਚ ਸਫ਼ਾਈ ਅਭਿਆਨ ਦੀ ਸ਼ੁਰੂਆਤ ਕੀਤੀ।



# स्वयंसेवकों ने पर्यावरण संरक्षण का दिया संदेश

जागरण संवाददाता, जगराओं : खालसा कालेज फार वूमैन सिधवां खुर्द के प्रिंसिपल डा. अमनदीप कौर की अध्यक्षता में एनएसएस प्रोग्राम अफसर के सहयोग से सात दिवसीय एनएसएस कैंप लगाया गया। स्वच्छ भारत और मेरी माटी मेरा देश विषय के तहत आयोजित इस कैंप की शुरूआत परमात्मा का ओट आसरा लेते हुए कालेज शब्द से हुई। प्रिंसिपल डा. अमनदीप कौर ने विद्यार्थियों को पर्यावरण की सांभ-संभाल और राष्ट्र प्रति सेवा के लिए हमेशा तैयार बर तैयार रहने की प्रेरणा दी।

प्रोग्राम अफसर डा.इंद्रजीत कौर ने एनएसएस थीम ,स्वच्छ भारत मेरी माटी मेरा देश पर अपने विचार प्रकट किए और वालंटियरों को समाज प्रति सेवा भावना के लिए उत्साहित किया। कैंप के संचालन के लिए वालंटियरों की विभिन्न कमेटियां बनाई गईं



खालसा कालेज फार वूमैन सिधवां खुर्द में आयोजित सात दिवसीय एनएसएस कैंप की विभिन्न गतिविधियों में भाग लेते वालंटियर व स्टाफ ● जागरण

जिसमें अनुशासन सभ्याचारक उपस्थिति रिपोर्ट और सफाई कमेटी आदि शामिल है। कैंप के पहले दिन वालंटियरों ने कालेज कैंपस में सफाई

अभियान की शुरूआत की। इसमें स्वयंसेवकों ने भाग लिया। इस मौके पर वालंटियरों के लिए रिफरेशमेंट का प्रबंध उच्च तौर पर किया गया।





ਕੈਂਪ ਦੇ ਅਖਰੀਲੇ ਦਿਨ ਵਿਦਿਆਰਥਣਾਂ ਦਾ ਸਨਮਾਨ ਕਰਦੇ ਹੋਏ ਕਾਲਜ ਦੇ ਪ੍ਰਿੰਸੀਪਲ ਡਾ: ਅਮਨਦੀਪ ਕੌਰ ਅਤੇ ਹੋਰ। ਤਸਵੀਰ: ਤੇਜਿੰਦਰ ਸਿੰਘ ਚੱਢਾ

## ਸਿੱਧਵਾਂ ਕਾਲਜ ਵਿਖੇ ਸੱਤ ਰੋਜ਼ਾ ਐੱਨ.ਐੱਸ.ਐੱਸ. ਕੈਂਪ ਸਫਲਤਾ ਪੂਰਵਕ ਸਮਾਪਤ

ਚੌਕੀਮਾਨ, 23 ਮਾਰਚ (ਤੇਜਿੰਦਰ ਸਿੰਘ ਚੱਢਾ)-ਖਾਲਸਾ ਕਾਲਜ ਫ਼ਾਰ ਵਿਮੈਨ ਸਿੱਧਵਾਂ ਖੁਰਦ ਦੇ ਪ੍ਰਿੰਸੀਪਲ ਡਾ: ਅਮਨਦੀਪ ਕੌਰ ਦੀ ਯੋਗ ਅਗਵਾਈ ਅਧੀਨ ਐੱਨ.ਐੱਸ.ਐੱਸ. ਯੂਨਿਟ ਵਲੋਂ ਆਯੋਜਿਤ 7 ਰੋਜ਼ਾ ਕੈਂਪ ਦੇ ਆਖਰੀ ਦਿਨ ਸੱਭਿਆਚਾਰਕ ਅਤੇ ਇਨਾਮ ਵੰਡ ਸਮਾਰੋਹ ਆਯੋਜਿਤ ਕੀਤਾ ਗਿਆ। ਪ੍ਰੋਗਰਾਮ ਅਫ਼ਸਰ ਡਾ: ਇੰਦਰਜੀਤ ਕੌਰ ਨੇ ਮੰਚ ਸੰਚਾਲਕ ਦੀ ਭੂਮਿਕਾ ਨਿਭਾਉਂਦਿਆਂ ਪ੍ਰਿੰਸੀਪਲ ਡਾ: ਅਮਨਦੀਪ ਕੌਰ ਨੂੰ ਜੀ ਆਇਆਂ ਕਿਹਾ। ਵਲੰਟੀਅਰ ਕਿਰਨਦੀਪ ਕੌਰ ਨੇ ਕਵਿਤਾ, ਨਜ਼ਮ ਅਤੇ ਰਮਨਪ੍ਰੀਤ ਕੌਰ ਨੇ ਐੱਨ.ਐੱਸ.ਐੱਸ. ਨਾਲ ਸਬੰਧਤ ਪੀ.ਪੀ.ਟੀ., ਅਰਸ਼ਦੀਪ ਕੌਰ ਨੇ ਸ਼ਹੀਦ-ਏ-ਆਜ਼ਮ ਭਗਤ ਸਿੰਘ ਦੀ ਸ਼ਹਾਦਤ ਬਾਰੇ ਭਾਸ਼ਣ ਅਤੇ ਕਸਿਬ, ਸ਼ਹਿਨਾਜ਼ ਅਤੇ ਮੁਸਕਾਨ ਕੌਰ ਨੇ ਐੱਨ.ਐੱਸ.ਐੱਸ. ਕੈਂਪ ਬਾਰੇ ਆਪਣੇ ਨਿੱਜੀ ਤਜਰਬਿਆਂ ਨੂੰ ਸਾਂਝਾ ਕੀਤਾ। ਕੈਂਪ ਦੌਰਾਨ ਬਣਾਈਆਂ ਗਈਆਂ

ਵਿਭਿੰਨ ਕਮੇਟੀਆਂ ਵਿਚੋਂ ਵਿਦਿਆਰਥਣਾਂ ਦੀ ਚੰਗੀ ਕਾਰਗੁਜ਼ਾਰੀ ਵਾਲੀਆਂ ਵਿਦਿਆਰਥਣਾਂ ਰਮਨਪ੍ਰੀਤ, ਮਨਪ੍ਰੀਤ, ਸਿਮਰਨਪ੍ਰੀਤ, ਮੁਸਕਾਨ, ਜੋਤੀ ਕੁਮਾਰੀ ਨੂੰ ਡਾਇਰੀਆਂ ਅਤੇ ਬਾਕੀ ਵਿਦਿਆਰਥਣਾਂ ਨੂੰ ਪੈਨ ਭੇਟ ਦਿੱਤੇ ਗਏ। ਇਸ ਮੌਕੇ ਸਰਵੋਤਮ ਵਲੰਟੀਅਰ ਯੂਨਿਟ-1 ਦੀ ਟਰਾਫੀ ਸ਼ਹਿਨਾਜ਼, ਯੂਨਿਟ-2 ਵਿਚ ਨਜ਼ਮ ਅਤੇ ਸਰਵੋਤਮ ਬੁਲਾਰੇ ਦੀ ਟਰਾਫੀ ਮਲਿਕਾ ਨੇ ਹਾਸਲ ਕੀਤੀ। ਵਿਦਿਆਰਥੀ ਸੰਵਾਦ ਮੁਕਾਬਲੇ ਵਿਚ ਨਵਦੀਪ ਕੌਰ ਨੇ ਪਹਿਲਾ, ਅਕਾਸ਼ਦੀਪ ਕੌਰ ਨੇ ਦੂਜਾ ਅਤੇ ਹਰਦੀਪ ਕੌਰ ਨੇ ਤੀਜਾ ਸਥਾਨ ਪ੍ਰਾਪਤ ਕਰਦਿਆਂ ਟੀਮ ਟਰਾਫੀ ਹਾਸਲ ਕੀਤੀ। ਵਲੰਟੀਅਰ ਮੁਸਕਾਨ ਅਤੇ ਸ਼ਹਿਨਾਜ਼ ਨੇ ਸੱਭਿਆਚਾਰਕ ਪ੍ਰੋਗਰਾਮ ਦੀ ਪੇਸ਼ਕਾਰੀ ਕੀਤੀ। ਪ੍ਰਿੰਸੀਪਲ ਡਾ: ਅਮਨਦੀਪ ਕੌਰ ਨੇ ਪ੍ਰੋਗਰਾਮ ਅਫ਼ਸਰ ਡਾ: ਇੰਦਰਜੀਤ ਕੌਰ ਅਤੇ ਸਮੂਹ ਵਲੰਟੀਅਰਾਂ ਨੂੰ ਕੈਂਪ ਦੀ ਸਫਲਤਾ ਪੂਰਵਕ ਸੰਪੰਨਤਾ ਲਈ ਵਧਾਈ ਦਿੱਤੀ।

On 22 March 2024 under the able guidance of the college Principal, Dr. Amandeep Kaur, Social Science Department organised 'World Water Day.' The theme for the year was 'Water for Prosperity and Peace.' An awareness rally on water conservation was organised. The students prepared posters on various themes like water, saving measures, water availability, water equity etc. A ppt on water conservation and saving measures was given by Dr Jasdeep Kaur. Dr Navdip Kaur shared her views on the current scenario of water availability and Bangalore water crisis. Mrs Karamdeep Kaur expressed her views on the topic 'Water Justice' and encouraged the students and faculty to save water and said that saving water is our fundamental duty. Mrs Hardeep Kaur thanked the faculty and students for sparing their valuable time.





World water day  
22-March-2024

By Social Science

Department  
Date  
Page No.

S.No.	Name	Class	Roll No	Sign
1.	Amandeep Kaur	B.A.I	29	Amandeep
2.	Jaismeen Kaur	B.A.I	64	Jaismeen Kaur
3.	Gungun	B.A.I	01	Gungun
4.	Harshreet Kaur	B.A.I	12	Harshreet Kaur
5.	Poojeep Kaur	B.A.I	40	Poojeep Kaur
6.	Swinderan Kaur	B.A.I	08	Swinderan Kaur
7.	Sukhmandeep Kaur	B.A.I	42	Sukhmandeep
8.	Gurinderan Kaur	B.A.I	76	Gurinderan Kaur
9.	Harmandeep Kaur	B.A.I	37	Harmandeep Kaur
10.	Simranjit Kaur	B.Com 1	1919	Simranjit Kaur
11.	Pooja	B.Com I	1950	Pooja
12.	Vishal Kaur	B.A.I	71	Vishal Kaur
13.	Harshpreet Kaur	B.Com I	1923	Harshpreet Kaur
14.	Pavneet	"	1918	Pavneet
15.	Amandeep Kaur	B.Com - I	1944	Amandeep Kaur
16.	Diya	B.Com - I	1921	Diya
17.	Simran Kaur	B.A.I	34	Simran Kaur
18.	Kirandeep Kaur	"	47	Kirandeep Kaur
19.	Simran	B.Com I	1937	Simran
20.	Sahilpreet Kaur	B.Com I	1928	Sahilpreet Kaur
21.	Pawandeep Kaur	B.Com I	1904	Pawandeep
22.	Harpreet Kaur	B.COM-I	1910	Harpreet Kaur
23.	Jasviri Kaur	B.com - I	1908	Jasviri Kaur
24.	Akashdeep Kaur	B.A. B.ed III	2808	Akash
25.	Lovejit Kaur	"	2808	Lovejit
26.	Sandeep Kaur	"	2807	Sandeep
27.	Amrinder Kaur	BA III	720	Amrinder
28.	Kashish	BA/BEd III	2303	Kashish
29.	Kiranjit Kaur	BA/BEd II	2258	Kiran
30.	Simranjit Kaur	B.A.II	409	Simranjit Kaur



S.No.	Name	Class	Roll No.	Sign
31	Aashdeep Kaur	BATI	404	Aashdeep Kaur
32	Jyoti Kumari	BATI	719	Jyoti Kumari
33	Jyoti Kumari	BATI	711	Jyoti Kumari
34	Simranpreet Kaur	BATI	710	Simranpreet K
35	Manpreet Kaur	BATI	718	Manpreet Kaur
36	Jaspreet Kaur	BA - BEd 3 year	2304	Jaspreet Kaur
37	Pooja	BATI	707	Pooja
38	Gurandeep Kaur	BATI	429	Gurandeep K.
39	Sukhmandeep Kaur	BA (II)	419	Sukhmandeep K
40	Rajandeep Kaur	BA (II)	427	Rajandeep K
41	Rajdeep Kaur	BA (II)	428	Rajdeep Kaur
42	Sumandeep Kaur	M.A I Pbi	2601	Sumandeep Kaur
43	Jashanpreet Kaur	M.A I Pbi	2603	Jashan
44	Samreen Kaur Bhullar	BA (II)	402	Samreen Kaur Bhullar
45	Palwinder Kaur	BATI	408	Palwinder Kaur
46	Gurmeet Kaur	BATI	410	Gurmeet Kaur
47	Anmolpreet Kaur	M.A. I Pbi	3201	Anmolpreet Kaur
48	Sukhpreet Kaur	BA. Bed 2	2204	Sukhpreet Kaur
49	Simranpreet Kaur	B.AE	34	Simranpreet Kaur
50	Bani	B.AE	50	Bani
51	Manpreet Kaur	B.AE	50	Manpreet Kaur
52	Muskan	B.AE	32	Muskan
53	Hardip Kaur	B.AE	2208	Hardip Kaur
54	Rajandip Kaur	B.AE	2203	Rajandip Kaur
55	Amarpreet Kaur	B.AE	2257	Amarpreet Kaur
56	Aashdeep Kaur	B.AE	228	Aashdeep Kaur
<u>Teacher:</u>	Dr. Hardeep Kaur	(HOD HS)		
	Mrs. Hardeep Kaur	(HS)		
	Dr. Jasdeep Kaur	(Eco)		
<u>PU</u>	Karamdeep Kaur	(PBI)		



# ‘ਪਾਣੀ ਕੁਦਰਤ ਦੀ ਵਡਮੁੱਲੀ ਦਾਤ, ਇਸ ਨੂੰ ਸੰਭਾਲਣਾ ਸਾਡਾ ਧਰਮ’



‘ਪਾਣੀ ਬਚਾਓ’ ਵਿਸ਼ੇ ‘ਤੇ ਰੈਲੀ ਕੱਢਣ ਮੌਕੇ ਵਿਦਿਆਰਥੀ ਤੇ ਸਟਾਫ਼ ਮੈਂਬਰ। (ਮਾਲਵਾ)

ਜਗਰਾਓਂ, 22 ਮਾਰਚ (ਮਾਲਵਾ)–  
ਖ਼ਾਲਸਾ ਕਾਲਜ ਫ਼ਾਰ ਵੂਮੈਨ ਸਿੱਧਵਾਂ ਖੁਰਦ  
ਦੇ ਸੋਸ਼ਲ ਸਾਇੰਸ ਵਿਭਾਗ ਵਲੋਂ ਪ੍ਰਿੰਸੀਪਲ  
ਡਾ. ਅਮਨਦੀਪ ਕੌਰ ਦੀ ਯੋਗ ਅਗਵਾਈ  
ਅਧੀਨ ‘ਵਾਟਰ ਫ਼ਾਰ ਪੀਸ’ ਵਿਸ਼ੇ ‘ਤੇ ਵਿਸ਼ਵ  
ਜਲ ਦਿਵਸ ਮਨਾਇਆ ਗਿਆ। ਇਸ ਮੌਕੇ  
ਵਿਦਿਆਰਥਣਾਂ ਨੇ ‘ਪਾਣੀ ਬਚਾਓ’ ਵਿਸ਼ੇ  
‘ਤੇ ਪੋਸਟਰ ਬਣਾਏ ਅਤੇ ਰੈਲੀ ਕੱਢੀ।

ਅਰਥਸ਼ਾਸਤਰ ਵਿਭਾਗ ਦੇ ਮੁਖੀ ਡਾ.  
ਜਸਦੀਪ ਕੌਰ ਨੇ ਵਿਦਿਆਰਥਣਾਂ ਨੂੰ ਪੀ.  
ਪੀ. ਟੀ. ਰਾਹੀਂ ਪਾਣੀ ਬਚਾਉਣ ਦੇ ਢੰਗ  
ਦੱਸੇ। ਇਤਿਹਾਸ ਵਿਭਾਗ ਦੇ ਮੁਖੀ ਡਾ.

ਨਵਦੀਪ ਕੌਰ ਨੇ ਵਿਦਿਆਰਥਣਾਂ ਨੂੰ  
ਸੰਬੋਧਨ ਕਰਦਿਆਂ ਦੱਸਿਆ ਕਿ ਪਾਣੀ  
ਕੁਦਰਤ ਦੀ ਵਡਮੁੱਲੀ ਦਾਤ ਹੈ, ਇਸ ਨੂੰ  
ਸੰਭਾਲਣਾ ਸਾਡਾ ਧਰਮ ਹੈ।

ਪ੍ਰੋ. ਕਰਮਦੀਪ ਕੌਰ ਨੇ ਦੱਸਿਆ ਕਿ  
ਪਾਣੀ ਦੀ ਸੰਭਾਲ ਕਰਨਾ ਸਾਡਾ ਮੌਲਿਕ  
ਕਰਤੱਵ ਹੈ। ਇਸ ਮੌਕੇ ਸਟਾਫ਼ ਅਤੇ  
ਵਿਦਿਆਰਥਣਾਂ ਨੂੰ ਭਵਿੱਖ ਵਿਚ ਪਾਣੀ  
ਬਚਾਉਣ ਦੀ ਸਹੁੰ ਚੁਕਾਈ ਗਈ। ਇਤਿਹਾਸ  
ਵਿਭਾਗ ਦੇ ਪ੍ਰੋ. ਹਰਦੀਪ ਕੌਰ ਨੇ ਸਭ ਦਾ  
ਧੰਨਵਾਦ ਕੀਤਾ। ਇਸ ਗਤੀਵਿਧੀ ਵਿਚ 56  
ਵਿਦਿਆਰਥਣਾਂ ਨੇ ਭਾਗ ਲਿਆ।

**Planting trees, nurturing freedom – A tribute to Freedom Fighters legacy.**

**Plantation Drive was carried out on  
Martyrdom Day of Shaheed Bhagat Singh, Rajguru and Sukhdev**



As per the directions of College Development Council, Panjab University, Chandigarh the Literary Society, NCC Unit and NSS Units of Khalsa College for Women, SidhwanKhurd observed Martyrdom Day of ShaheedBhagat Singh, Rajguru and Sukhdevon **March 22-23, 2024** by organizing various events to commemorate the life and contribution of the Martyrs. On **March 22, 2024** a Cycle Rally was organized at village SidhwanKhurd in which students fervently participated. A symposium was held in which students shared their views on the legacy and contemporary significance bequeathed by the patriots. Plantation Drive was carried out and rally to create awareness on Drug Menace and other social evils was taken out at village SidhwanKhurd on **March 23, 2024**.